

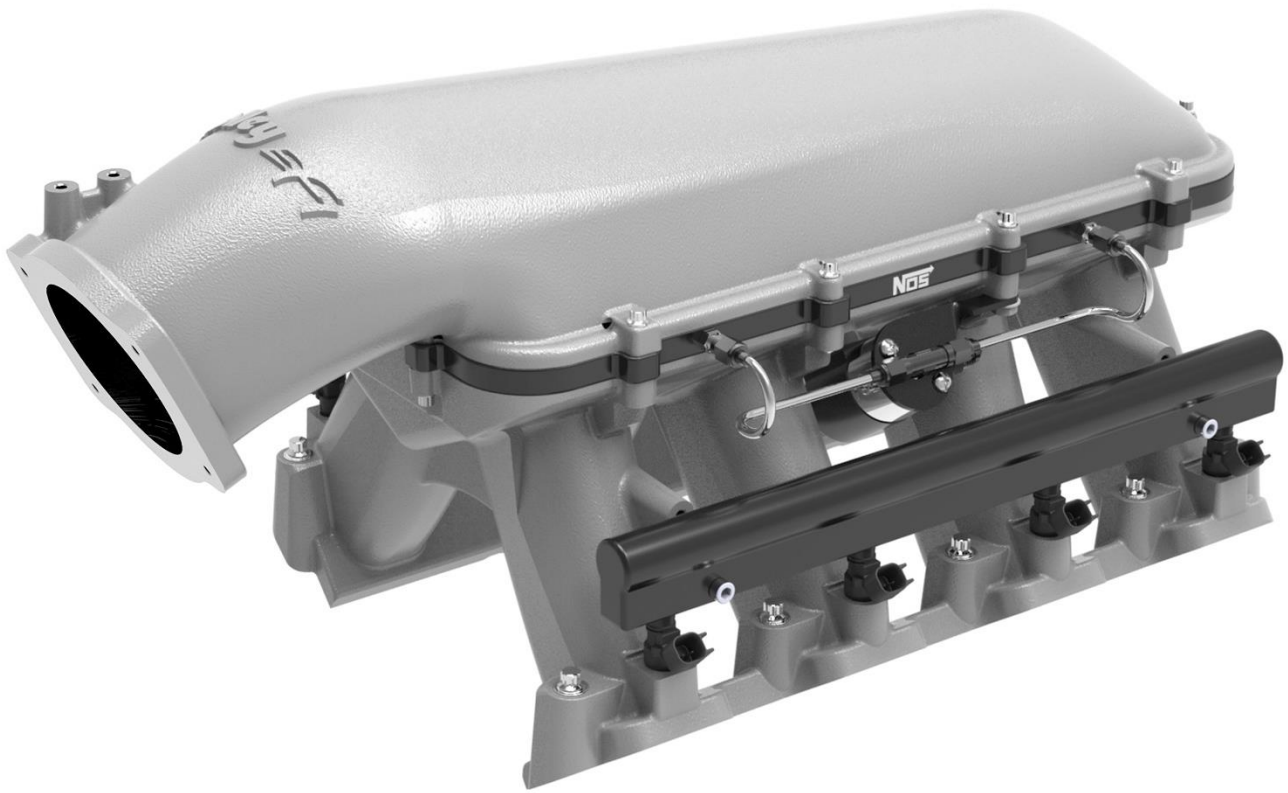

Billet Aluminum Holley Hi-Ram Dry Nitrous Plate

12535NOS, 12535BNOS, 05500NOS, 05500BNOS, 05501NOS, 05501BNOS, & 05502NOS



OWNER'S MANUAL

CONGRATULATIONS on purchasing your NOS Nitrous Oxide Injection System! Your system is composed of the highest quality components available. It should provide many miles of trouble-free performance when used correctly. If you have any questions regarding the performance of your system, call **NOS Technical Service** at 1-866-464-6553 or for online help, refer to the **Tech Service** section of our website: www.holley.com.

NOTICE: The installation of Nitrous Oxide Systems, Inc. products signifies that you have read this document and have agreed to the terms stated within.

It is the purchaser's responsibility to follow all installation instruction guidelines and safety procedures supplied with the product as it is received by the purchaser to determine the compatibility of the product with the vehicle or the device the purchaser intends to install the product on.

Nitrous Oxide Systems Inc. assumes no responsibility for damages occurring from accident, misuse, abuse, improper installation, improper operation, lack of reasonable care, or all previously stated reasons resulting from incompatibility with other manufacturers' products.

Nitrous Oxide Systems Inc. assumes no responsibility or liability for damages incurred by the use of products manufactured or sold by Nitrous Oxide Systems Inc. on vehicles used for competition or racing.

Nitrous Oxide Systems Inc. neither recommends nor condones the use of products manufactured or sold by Nitrous Oxide Systems Inc. on vehicles, which may be driven on public roads or highways, and assumes no responsibility for damages incurred by such use.

NOS nitrous oxide is legal for use in most states when used in accordance with state and local traffic laws. NOS does not recommend or condone the use of its products in illegal racing activities.

NOS has not pursued California Air Research Board (CARB) exemptions for its kits, hence, they are not legal for use on pollution-controlled vehicles in California. A correctly installed NOS nitrous system should not alter the emission control performance of your vehicle under standard EPA test cycle conditions.

HAZARDS DEFINED

This manual presents step-by-step instructions that describe the process of installing your NOS Nitrous Oxide Injection System. These procedures provide a framework for the installation and operation of this kit. Parts are referenced by name and number to avoid confusion. Within the instructions, you are advised of potential hazards, pitfalls, and problems to avoid. The following examples explain the various hazard levels:

WARNING! Failure to comply with instructions may result in injury or death.

CAUTION! Failure to comply with instructions may result in damage to equipment.

NOTE: This information is important, needs to be emphasized, and is set apart from the rest of the text.

HINT: These special instructions provide a handy work tip.

NITROUS OXIDE INJECTION SYSTEM SAFETY TIPS

WARNINGS

IT IS NOT LEGAL TO ENGAGE NITROUS OXIDE INJECTION SYSTEMS ON PUBLIC ROADS OR HIGHWAYS. NITROUS OXIDE INJECTION SYSTEMS ARE ONLY TO BE ENGAGED DURING SANCTIONED COMPETITION OR RACING EVENTS.

Do not attempt to start the engine if the nitrous has been injected while the engine was not running. Disable the ignition and fuel systems (consult owner's manual) and turn the engine over with the throttle wide open for several revolutions before attempting to start. Failure to do so can result in extreme engine damage.

Never permit oil, grease, or any other readily combustible substances to come in contact with cylinders, valves, solenoids, hoses, and fittings. Oil and certain gases (such as oxygen and nitrous oxide) may combine to produce a highly flammable condition.

Never interchange nitrous and fuel solenoids. Failure to follow these simple instructions can result in extreme engine damage and/or personal injury.

Never drop or violently strike the bottle. Doing so may result in an explosive bottle failure.

Never change pressure settings of safety relief valve on the nitrous bottle valve. Increasing the safety relief valve pressure settings may create an explosive bottle hazard.

Please note that the NOS bottle label has changed to a two-part assembly. The first label is already located on the bottle. Upon filling your bottle with nitrous oxide, apply the (second) material information label in the area indicated in the picture to the right.

NOTE: The material information decal is located in the same plastic bag as the bottle.

WARNING! Once the nitrous bottle has been filled, it must be shipped according to the applicable transportation and shipping regulations!

Do not deface or remove any markings, which are used for content identification.

Nitrous bottle valves should always be closed when the system is not being used.

Notify the supplier of any condition that may have permitted any foreign matter to enter the valve or bottle.

Keep the valves closed on all empty bottles to prevent accidental contamination.

After storage, open the nitrous bottle valve for an instant to clear the opening of any possible dust or dirt.

It is important that all threads on the valves and solenoids are properly mated. Never force connections that do not fit properly.



TABLE OF CONTENTS

WHAT IS NITROUS OXIDE?	4
DO'S AND DON'TS OF NITROUS OXIDE	4
Chapter 1 Introduction to Your NOS Nitrous Oxide Kit	4
1.1 General Information	4
1.2 System Requirements	5
1.3 Kit Components	5
Chapter 2 Kit Installation	7
2.1 Bottle Mounting Instructions	7
2.2 Bottle Orientation	7
2.3 Bottle Installation	7
2.4 Solenoid Fittings and Bracket Mounting	8
2.5 Kit Plate Installation	8
2.6 Nitrous Supply Connection	12
2.7 Electrical System	12
2.8 Preparing for Operation	13
Chapter 3 Tuning	14
Chapter 4 Determining Optimum System Performance	14
Chapter 5 Alternate Sensor, Actuator, and Switch Components	15
Chapter 6 Routine Maintenance	16
6.1 Nitrous Solenoid Filter	16
6.2 Nitrous Solenoid Plunger	16
6.2.1 General Information	16
6.2.2 Nitrous Solenoid Plunger Disassembly and Inspection	16
Appendix A Troubleshooting Guide	17
Nitrous Oxide Accessories	19

WHAT IS NITROUS OXIDE?

NITROUS OXIDE...

...Is a cryogenic gas composed of nitrogen and oxygen molecules

...Is 36% oxygen by weight

...Is non-flammable by itself

...Is stored as a compressed liquid

...Exists in two grades—U.S.P. and Nitrous Plus:

- ❑ U.S.P. is medical grade nitrous oxide; its common use is dental and veterinary anesthesia. It is also commonly used as a propellant in canned whipped cream. U.S.P. is not available to the public.
- ❑ Nitrous Plus differs from U.S.P. in that it contains trace amounts of sulphur dioxide added to prevent substance abuse. Nitrous Plus is intended for automotive applications and is available for sale to the public.

In automotive applications, Nitrous Plus and fuel are injected into the engine's intake manifold, producing the following results:

- ❑ Lowers engine intake air temperature, producing a dense inlet charge.
- ❑ Increases the oxygen content of the inlet charge (air is only 22 percent oxygen by weight).
- ❑ Increases the rate at which combustion occurs in the engine's cylinders.

DO'S AND DON'TS OF NITROUS OXIDE

Do's

- ❑ Read all instructions before attempting to install your NOS nitrous system.
- ❑ Make sure your fuel delivery system is adequate for the nitrous jetting you have chosen. Inadequate fuel pressure or flow will result in engine damage.
- ❑ Use 14 gauge (minimum) wire when installing electrical system components.
- ❑ Use high-quality connections at all electrical joints.
- ❑ Use PTFE-based thread sealant on pipe-style fittings.
- ❑ Make sure your engine and related components (ignition, fuel system, and driveline) are in proper working condition.
- ❑ **Do not attempt to start the engine if the nitrous has been injected while the engine was not running. Disable the ignition and fuel systems (consult owner's manual) and turn the engine over with the throttle wide open for several revolutions before attempting to start. Failure to do so can result in extreme engine damage.**
- ❑ **Use your NOS nitrous system only at wide-open throttle and at engine speeds above 3000 RPM.**
- ❑ **Install a proper engine to chassis ground. Failure to do so may result in an explosive failure of the main nitrous supply line.**
- ❑ Use a high-quality fuel, as suggested in Chapter 3, Baseline Tuning Suggestions.

Don'ts

- ❑ Engage your nitrous system with the engine off. Severe engine damage can occur.
- ❑ Modify NOS nitrous systems (if you need a non-stock item, call NOS Technical Service for assistance)
- ❑ Overtighten AN type fittings.
- ❑ Use PTFE Tape on any pipe threads. Pieces of PTFE tape can break loose and become lodged in the nitrous or fuel solenoids or solenoid filters. Debris lodged in a nitrous or fuel solenoid can cause catastrophic engine failure.

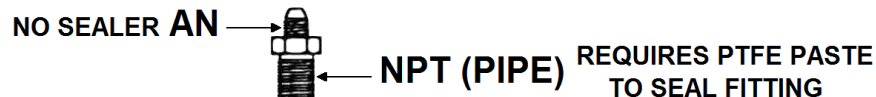

- ❑ Use sealant of any kind on AN type fittings.
- ❑ Allow nitrous pressure to exceed 1100 psi. Excessive pressure can cause swelling or in extreme cases failure of the nitrous solenoid plunger. Solenoid plungers are designed so that pressure-induced failures will prevent the valve from operating. No leakage should occur with this type of failure.
- ❑ **Inhale nitrous oxide. Death due to suffocation can occur.**
- ❑ **Allow nitrous oxide to come in contact with skin. Severe frostbite can occur.**
- ❑ **Use octane boosters that contain methanol. Fuel solenoid failure may occur, producing severe engine damage.**

Chapter 1 Introduction to Your NOS Nitrous Oxide Kit

1.1 General Information

The Holley Hi-Ram Dry Sandwich Plate Kit was engineered to be a clean and simple installation on an LS powered vehicle that utilizes a Holley Hi-Ram Intake Manifold. Power output can be increase from 50 to 150 Rear Wheel Horse Power (RWHP) with the supplied jetting. The system can support up to 500+ RWHP with optional jetting, but be aware that an increase over 150 RWHP will require an upgrade to the OEM fuel system in the form of an increased capacity fuel pump or a dedicated, stand-alone, fuel system.

1.2 System Requirements

The Holley Hi-Ram Dry Sandwich Plate Kit is designed to work with an LS powered vehicle which utilizes a Holley Hi-Ram Intake Manifold. Since this is a dry nitrous injection plate, the fuel enrichment must be provided by a standalone engine management system such as the Holley EFI Dominator or HP ECUs.

1.3 Kit Components

Before beginning the installation of your NOS kit, compare the components in your kit with those listed in **Table 1**. If any components are missing, please contact NOS Technical Support at 1-866-464-6553.

Table 1 – NOS Holley Hi-Ram Nitrous Plate Parts List

Item	Description	Qty	05500NOS	05500BNOS	05501NOS	05501BNOS	05502NOS
(1)	Bottle Nut Adapter	1	16230NOS	16226NOS	16230NOS	16226NOS	16226NOS
(2)	Bottle Valve Washer	1	16210NOS	16210NOS	16210NOS	16210NOS	16210NOS
(3)	Nitrous Bottle w/Racer Safety	1	14745-TPINOS	14745B-TPINOS	14750-ZR1NOS	14750B-ZR1NOS	14748NOS
(4)	Blow Down Tube	1	16160NOS	16161NOS	16160NOS	16161NOS	16161NOS
(5)	Bottle Mounting Bracket, Short	1	14126-SNOS	14126-SNOS	14126-SNOS	14126-SNOS	14126-SNOS
(6)	Bottle Mounting Bracket, Long	1	14127-SNOS	14127-SNOS	14127-SNOS	14127-SNOS	14127-SNOS
(7)	Pro-Race N ₂ O Solenoid	2	18048RNOS	18048RBNOS	18048RNOS	18048RBNOS	18048RBNOS
(8)	Relay Wiring Harness	1	15604-SNOS	15604-SNOS	15604-SNOS	15604-SNOS	15604-SNOS
(9)	30 Amp Relay	1	15618-SNOS	15618-SNOS	15618-SNOS	15618-SNOS	15618-SNOS
(10)	Straight 6AN –1/4" NPT Nitrous Filter	2	17980NOS	17979NOS	17980NOS	17979NOS	17979NOS
(11)	3AN – 1/8" NPT Tee	2	17250NOS	17249NOS	17250NOS	17249NOS	17249NOS
(12)	1/8 NPT Plug	2	7R1004	7R1004	7R1004	7R1004	7R1004
(13)*	0.016" Flare Jet	4	13760-16NOS	13760-16NOS	13760-16NOS	13760-16NOS	13760-16NOS
(14)*	0.023" Flare Jet	4	13760-23NOS	13760-23NOS	13760-23NOS	13760-23NOS	13760-23NOS
(15)*	0.029" Flare Jet	4	13760-29NOS	13760-29NOS	13760-29NOS	13760-29NOS	13760-29NOS
(16)*	0.033" Flare Jet	4	13760-33NOS	13760-33NOS	13760-33NOS	13760-33NOS	13760-33NOS
(17)*	0.037" Flare Jet	4	13760-37NOS	13760-37NOS	13760-37NOS	13760-37NOS	13760-37NOS
(18)	6AN 14 ft. Hose	1	15475NOS	15475BNOS	15475NOS	15475BNOS	15475BNOS
(19)	3AN to 3AN Stainless Nitrous Hard Line 1	1	52R707A	52R705A	52R707A	52R705A	52R705A
(20)	3AN to 3AN Stainless Nitrous Hard Line 2	1	52R708A	52R706A	52R708A	52R706A	52R706A
(21)	6AN to 6AN 18 inch Hose	2	15405NOS	15405BNOS	15405NOS	15405BNOS	15405BNOS
(22)*	Holley Hi-Ram Plate Assembly	1	701R517A	701R516A	701R517A	701R516A	701R516A
(23)	Screws, Solenoid Mounting 10-32	4	16501-SNOS	16501-SNOS	16501-SNOS	16501-SNOS	16501-SNOS
(24)*	3/32" Round Viton O-Ring Cord	4.5-ft	27R1042	27R1042	27R1042	27R1042	27R1042
(25)	Solenoid Mounting Bracket	2	49R3498	49R3498	49R3498	49R3498	49R3498
(26)*	Alloy-Steel 12-Point Screw, 1/4-20 x 1-1/2" Long	10	5R2635	5R2635	5R2635	5R2635	5R2635
(27)*	Alloy-Steel 12-Point Screw, 1/4-20 x 1-3/4" Long	2	5R2636	5R2636	5R2636	5R2636	5R2636
(28)*	1/4-20 Low Profile Nut	2	39R506	39R506	39R506	39R506	39R506
(29)	6AN Y-Block	1	17835NOS	17835BNOS	17835NOS	17835BNOS	17835BNOS
(30)	Drive By Wire – Electrical Kit	1	85R9801	85R9801	85R9801	85R9801	85R9801
	Rocker Switch	1					
	1/4" Ring Terminal – Red – 18-20 AWG	1					
	1/4" Female Spade – Red – 18-20 AWG	3					
	25 Amp Fuse ATC (large)	1					
	15 Amp Fuse ATM (mini)	1					
	Add-A-Fuse Tap for Mini ATM Fuses	1					
	Posi-Lock Splice Connector 22-20 AWG	4					
	5/16" Ring Terminal – Yellow – 10-12 AWG	2					
	5/16" Ring Terminal – Red – 18-20 AWG	1					
	Posi-Twist Connector 10-22 AWG	2					
	Wire – Red – 20AWG	8ft					
	Wire – Black – 20AWG	8ft					

*-Included in the Plate Only Kit

Chapter 2 Kit Installation

2.1 Bottle Mounting Instructions

Accurate calibration of your NOS nitrous system depends on the bottle remaining at a stable temperature. Mount the bottle away from heat sources, such as the engine compartment or exhaust system, and away from windows, where the bottle is exposed to direct sunlight.

2.2 Bottle Orientation

Bottle placement is critical to the performance of your NOS nitrous system. It is important to understand how the bottle valve and siphon tube are assembled to properly orient the bottle in your vehicle and ensure that it picks up liquid nitrous while undergoing acceleration. All nitrous bottles are assembled so that the bottom of the siphon tube is at the bottom of the bottle and opposite the bottle label (Figure 2).

Whenever the bottle is mounted in a lay-down position, the valve handle must be towards the front of the vehicle with the label facing up (Figure 3A).

If the bottle is mounted vertically, the valve handle and label must face toward the front of the vehicle (Figure 3B). This orientation will position the siphon tube at the back of the bottle where the liquid N₂O will be during acceleration.

WARNING! DO NOT attempt to remove the siphon tube without completely emptying the bottle of all N₂O and pressure.

A bottle mounted upside-down must have the siphon tube removed before use (Figure 3C). Non-siphon bottles can be specially ordered from NOS.

If the bottle must be mounted parallel to the axles of the vehicle (sideways), the valve handle and label must be angled at approximately 45° toward the front of the vehicle (Figure 3D). This orientation will position the siphon tube toward the rear of the bottle.

NOTE: When using a bottle with a siphon tube, the tall bracket should be at the valve end of the bottle and the short bracket at the bottom (Figure 3E).

The most efficient mounting is the lay-down position (Figure 3A) with the valve handle toward the front of the vehicle. This position allows the greatest amount of liquid to be used before the siphon tube begins to pick up gaseous nitrous oxide.

Find a position in the rear of your vehicle that meets your personal preference. Make sure that it meets the guidelines show in Figure 3.

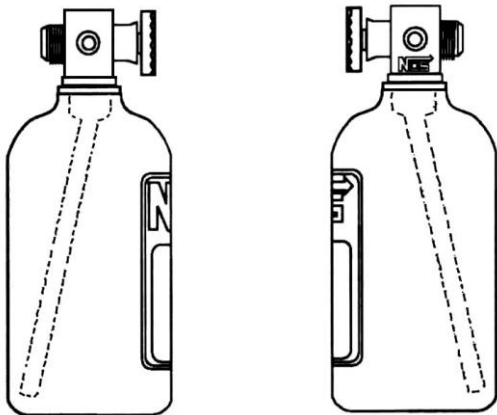

Figure 2 Nitrous Bottle Siphon Tube Orientation

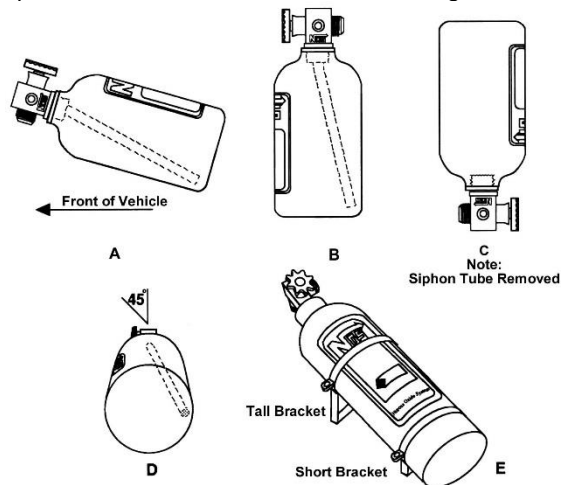

Figure 3 Nitrous Bottle Mounting Orientations

2.3 Bottle Installation

Before mounting a nitrous bottle in a racing vehicle intended for use in sanctioned events, check with the sanctioning association for any rules regarding this subject. Most associations require the bottle to be mounted within the confines of the safety roll cage with the safety pressure relief cap vented away from the driver's compartment. This feature is included in this kit.

1. Install the bottle nut adapter and washer on the nitrous bottle, and tighten securely.
2. Slip the bottle mounting brackets onto the nitrous bottle, as shown in Figure 3E.

3. Locate the bottle assembly in the desired mounting location, ensuring that the location will provide easy access to the bottle valve, hose connection, bracket clamp bolts to facilitate bottle changing and through hole of the blow-down tube.
4. Use the assembled bottle/bracket unit as a pattern to mark for drilling the holes. Drill four 11/32" holes in the mounting surface for the bottle bracket bolts. **Make sure the holes are in a position that does not damage other components.**

CAUTION! When drilling or punching holes for these fasteners, be aware what components, wires, hoses or fluid reservoirs are located or routed behind the general area to avoid vehicle or equipment malfunction.

5. Mount the brackets securely to the surface (recommended minimum of 5/16" bolts or No. 12 sheet metal screws).
6. Secure the nitrous bottle in the mounting brackets and tighten the bracket clamps.
7. Route the blow-down tube through the hole in the trunk, install and fasten to the fitting on the bottle valve.

2.4 Solenoid Fittings and Bracket Mounting

1. Apply a small amount of PTFE thread sealant to the NPT threads of the **nitrous inlet filter adapter** (-6AN to 1/4 NPT straight adapter with screen) and insert into the **IN** side of the nitrous solenoid. Use a bench vise to tighten the fitting at least 1-1/2 turns after finger tight. See **Figure 4**.
2. Insert the 1/8 NPT plug into the **OUT** side of the nitrous solenoid (unless you plan on installing a nitrous purge valve). Use a bench vise to tighten the fitting at least 1-1/2 turns after finger tight. See **Figure 4**.

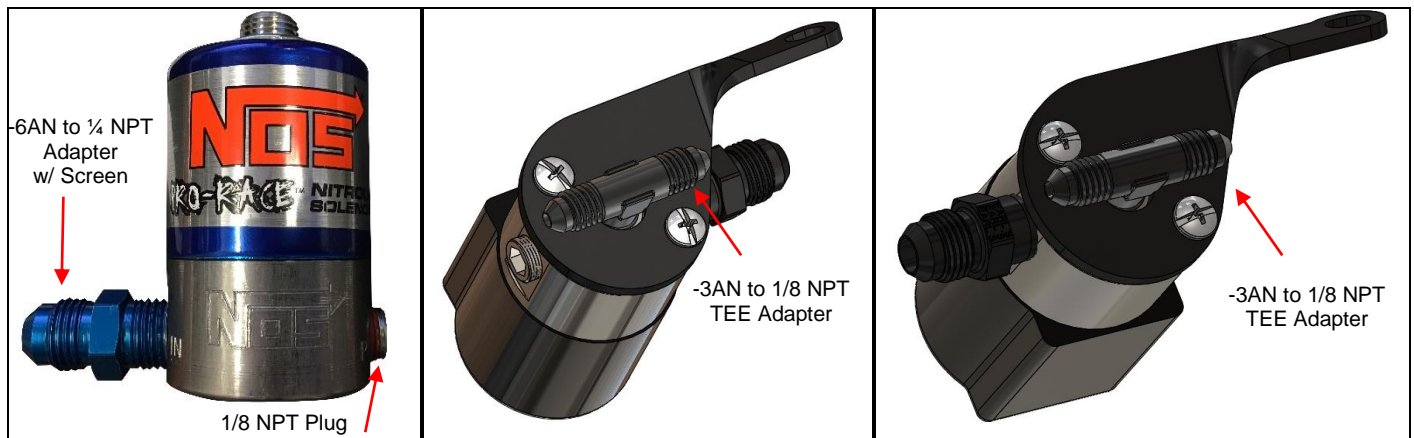

Figure 4 – Solenoid Assembly

Figure 5 – Drivers Side Bracket Mount

Figure 6 – Passengers Side Bracket Mount

3. Attach the solenoid bracket to the nitrous solenoid with the supplied screws. **NOTE: Be sure to orientate the solenoid according to the correct side of the engine.**
4. Apply a small amount of PTFE thread sealant to the NPT threads of the **nitrous outlet adapter** (3AN to 1/8 NPT TEE adapter without screen) and insert into the **OUT** side (bottom) of the nitrous solenoid. Use a bench vise to tighten the fitting at least 1-1/2 turns after finger tight, see **Figure 5** for alignment for the driver's side.
5. Apply a small amount of PTFE thread sealant to the NPT threads of the **nitrous outlet adapter** (3AN to 1/8 NPT TEE adapter without screen) and insert into the **OUT** side (bottom) of the nitrous solenoid. Use a bench vise to tighten the fitting at least 1-1/2 turns after finger tight, see **Figure 5** for alignment for the passenger's side.

2.5 Kit Plate Installation

WARNING! Do not smoke, carry lighted tobacco, or allow an open flame of any type when working on or near any fuel-related components. Highly flammable mixtures are always present and may be ignited. Failure to follow these instructions may result in personal injury.

1. Disconnect negative cable at the battery.
2. Disconnect the throttle body connections (TPS, IAC, DBW, etc.) and linkage.

3. Remove any couplers/intake tubes from the throttle body.
4. Remove the 12 ¼-20 x 7/8" bolts following the sequence shown in figure 7. And remove the plenum top.

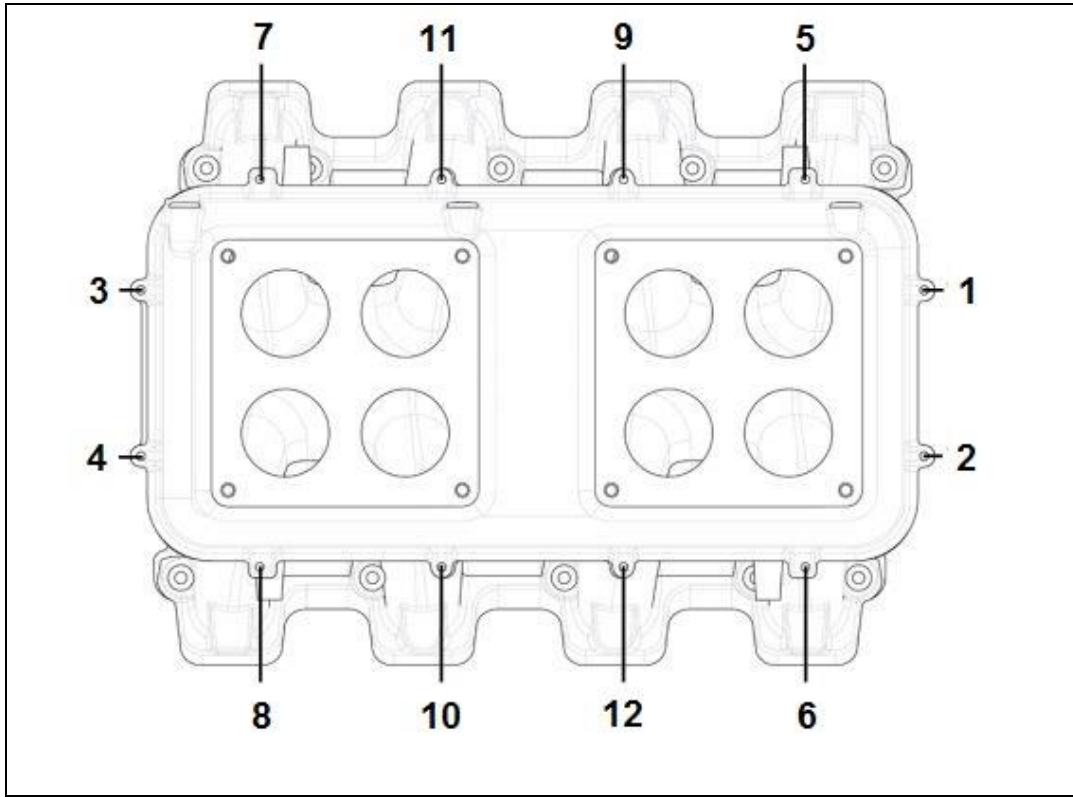

Figure 7 – Plenum Top Removal Sequence

5. The following steps will guide you through the O-ring installation for the NOS Hi-Ram Nitrous Plate.
 - a) Before installing the nitrous plate, the supplied O-ring cord will need to be cut to length and glued together.
 - b) Lay the O-ring cord into the groove on the nitrous plate with the free end overlapped.
 - c) Mark the position of the cut to be made across both O-ring ends.
 - d) Lay the O-ring on a flat surface with the ends overlapped and the marks aligned as they were when the marks were made.
 - e) With a sharp razor blade cut thru both ends of the O-ring at the mark simultaneously.
 - f) With a drop of super glue (Cyanoacrylate), bond the ends of the O-ring together. The glued joint should be smooth, not offset or kinked.
 - g) To ensure sealing at the glued joint, apply a thin film of silicone sealer around the O-ring at the glued joint, allowing the silicone to partially cure before installation of the O-ring in the groove.
 - h) Install the O-ring in the groove of the nitrous plate.
6. With the NOS logo facing up plate the NOS Hi-Ram Nitrous Plate onto the top of the manifold base as shown in Figure 8.

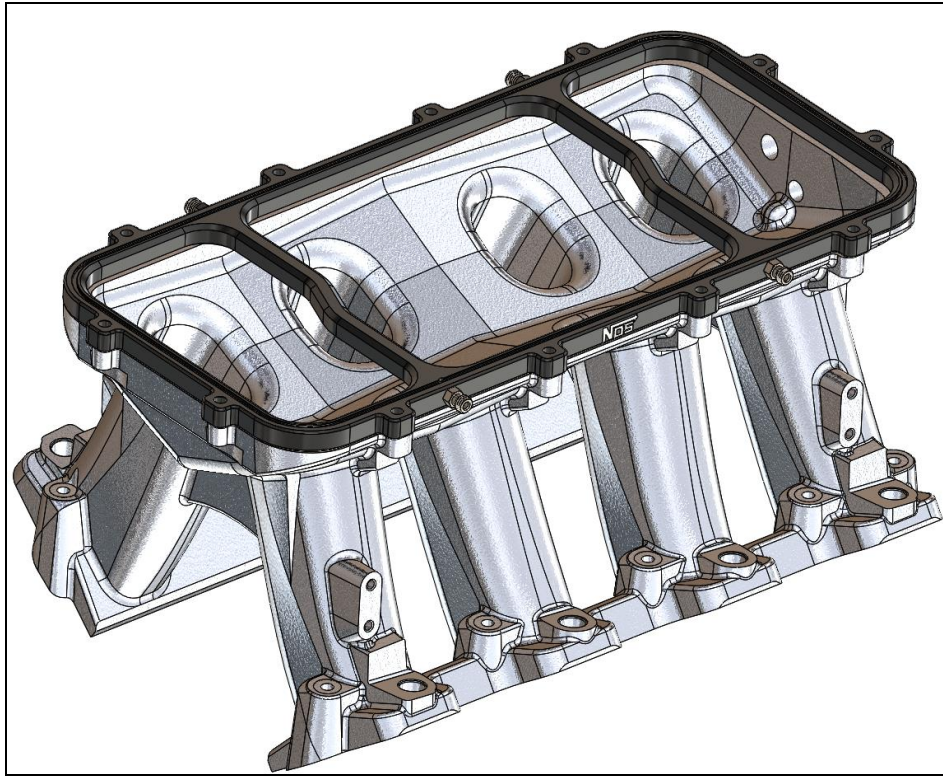

Figure 8 – Nitrous Plate Installation

7. Install the hardware provided with the NOS Hi-Ram Nitrous Plate Kit; anti-seize should be applied to the threads. Gently tighten the nuts working side to side and out from center (see the tightening sequence diagram in Figure 9), until manifold is seated on the mounting flanges and the O-ring has been compressed. In two steps, tighten the mounting nuts first to 50 in-lbs and then to 106 in-lbs. **NOTE: There are 2 longer bolts included in your kit those will be used to hold the solenoid brackets in place and the location of those bolts is highlighted in figure 9.**

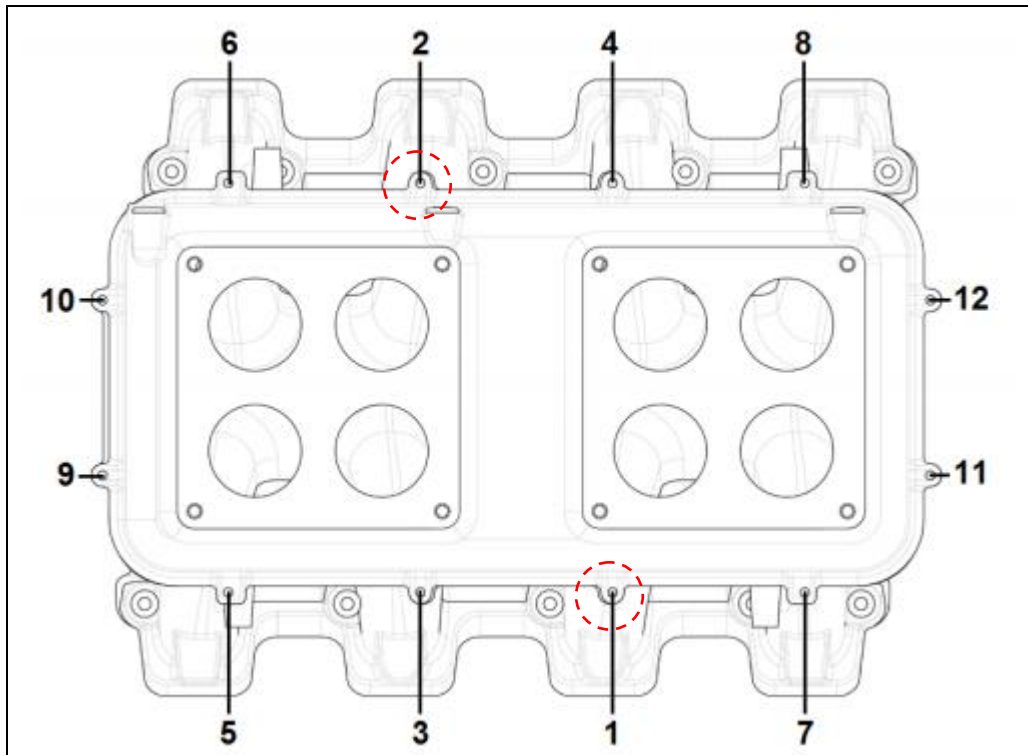

Figure 9 – Manifold Top Tightening Sequence

8. Once the manifold has been reassembled with the NOS Hi-Ram Nitrous Plate, we can proceed with the installation of the solenoid and bracket assemblies. **Figure 11** and **12** show each assembly located and secured with the supplied low profile nut. **NOTE: At this point do not fully tighten the low profile nut, adjustment may be required when installing the nitrous supply hardline in the next step.**

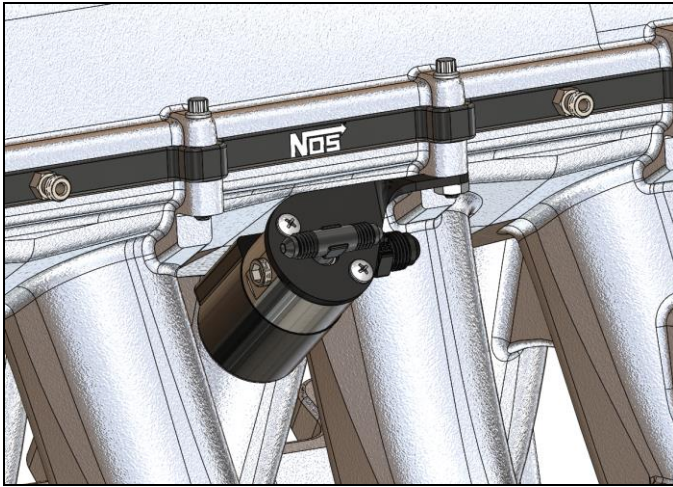

Figure 11 – Driver Side Solenoid Mounting



Figure 12 – Passenger Side Solenoid Mounting

NOTE: We highly recommend the smallest (lowest power) jetting supplied as a starting point. Once total system functionality has been verified, then larger jetting can be installed.

9. Install the desired jets and nitrous supply hardlines as shown in figure 13. Once you have lined up the hardlines secure the low profile nut that is retaining the solenoid bracket to 106 in-lbs. Finally tighten the -3AN hardline nuts to the tee and jet holders.

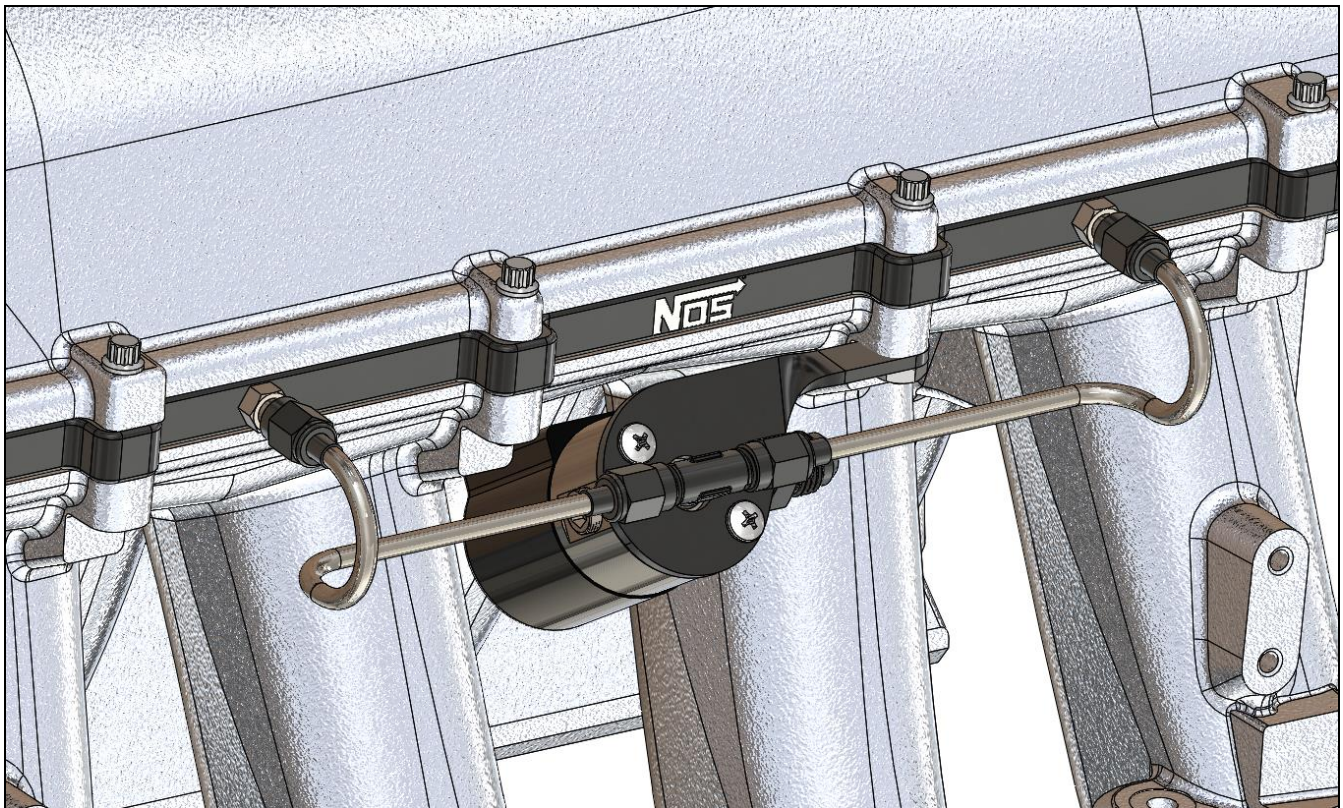

Figure 13 – Nitrous Supply Line Installation

2.6 Nitrous Supply Connection

1. Route the supplied -6AN nitrous hose from the bottle to the Y-block. Be sure to avoid any sources of high heat, vibration, or anything that rotates or moves such as suspension or drive shafts/axles. Make sure to secure the hose to the body of the vehicle so that it doesn't hang.
2. From the -6AN Y-Block route the two 18 inch -6AN nitrous hoses to each nitrous solenoid.
3. Finally tighten all nitrous hose connections.

2.7 Electrical System

WARNING! Death or injury may occur from working on a charged electrical system.

NOTE: The NOS Hi-Ram Nitrous Plate has been designed to be a DRY nitrous injection system. This requires fuel enrichment to be performed by the vehicles ECU. We recommend using a Holley EFI Dominator or HP ECU to do this.

The following reviews how to properly wire a nitrous oxide system in a generic standalone ECU (Refer to owner's manual for and in depth review for your specific ECU)

Required Wiring

An enable/arming input is required. It can be a ground or +12v input (make sure to configure in the software). The primary activation is the TPS and Engine Speed, both of which should be existing inputs.

GPO's

General Purpose Outputs (GPO's), which are optional, can be configured in the software. They are a +12v or ground output that can be used to trigger another device (ignition box timing retard, etc).

Input #1, #2, #3 – Three additional inputs can be wired in order to activate or deactivate nitrous. They work in conjunction with the TPS and Engine Speed activation settings. These three inputs are optional. An example would be to enable one off the trans-brake such that nitrous is NOT activated when the trans-brake is applied. They can be configured as a ground or +12v input in the software.

***Non-Progressive Wiring** – Any non-progressive stage of nitrous can be wired with a conventional switching relay (**Which is included with this kit**). The ECU will trigger the relay to activate the stage.

****Progressive Wiring** – A regular switching relay should never be used for progressive nitrous operation (other than for supplying constant power, it should never be "pulsed"). Figure 14 shows the proper wiring for a single stage non-progressive system. For additional stages, additional driver modules are required. **Note: PN 15620NOS MUST be used for a progressive nitrous system.**

NOTE: NEVER have the ECU directly power a nitrous oxide solenoid. All nitrous solenoids require more than the 2A rating for the ECU outputs.

* - Included in kit.

** - Optional, requires 15620NOS

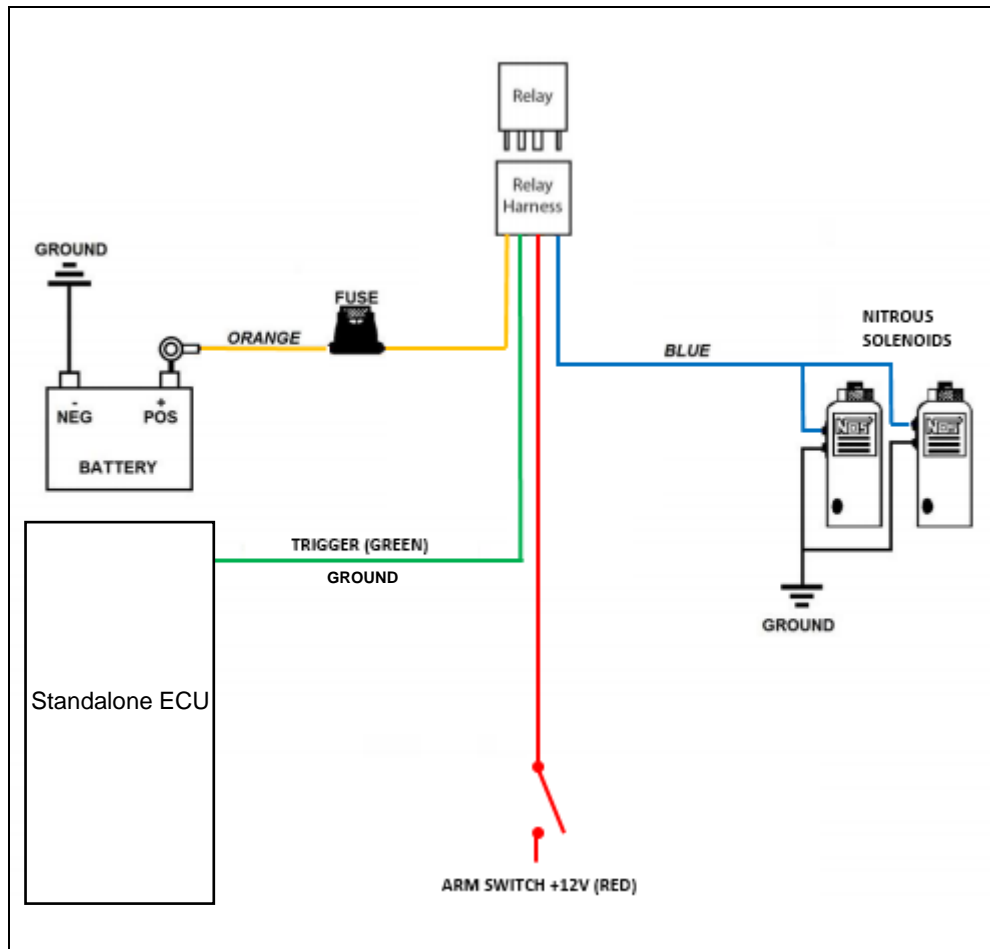

Figure 14 – Relay Wiring

2.8 Preparing for Operation

1. Install a fully charged nitrous bottle. The pressure gauge should read 900-1000 psi at operating temperature/pressure.
2. Slowly open the nitrous bottle valve while listening and looking for any leaks at the bottle fittings as well as the fittings on the solenoids in the engine compartment.
3. If no leaks are found, slightly loosen the -6 AN supply line fitting at the blue nitrous solenoid. Allow the air to leak from the fitting until nitrous starts to fog out, then retighten the fitting. **NOTE: Nitrous is very cold and can cause burning and irritation to the skin, we recommend wearing gloves during this procedure.**
4. Turn the ignition power to the ON position, but do not start the car.
5. Turn the Master Enable switch to the ON position. The red LED should be on now.
6. Once programming is complete, turn the ignition switch off for 10 seconds, then back to the ON position; do not start the engine yet.
7. Verify the ECU software display shows **active**. If display show any other values than **active** check connections or wiring.
8. You are now ready to drive the car and test the operation of the nitrous system.

WARNING! It is **VERY** important to use caution and good safety practices when testing and using any nitrous oxide system. We do not recommend the use of nitrous on any public streets or highways. It is recommended to only test and use nitrous in a controlled, closed course location, such as a race track.

WARNING! Never activate nitrous with the vehicle in “NEUTRAL” or “PARK”!

WARNING! Never activate nitrous at engine speeds below 3000 RPM, or engine damage may result!

WARNING! SEVERE ENGINE DAMAGE MAY OCCUR IF NITROUS IS ACTIVATED WHILE TRACTION CONTROL DEVICES ARE ENABLED. TRACTION CONTROL DE-ACTIVATION MUST BE CYCLED EVERY TIME THE IGNITION SWITCH IS CYCLED.

Chapter 3 Tuning

Table 2 Tuning Suggestions for the NOS Hi-Ram Nitrous Kit

Configuration	N ₂ O Jetting	Configuration	N ₂ O Jetting
50 HP	.016	200 HP	.033
100 HP	.023	250 HP	.037
150 HP	.029		

NOTE: This test was performed on a LSX376-B15 crate engine from GM Performance (Specs found here: <https://www.chevrolet.com/performance/crate-engines/lxs-376-b15>) using Pro Nitrous Extreme (123 Octane) race fuel from Renegade Fuel, NGK spark plugs, Hooker Long Tube headers, 60 lb/hr fuel injectors and Holley Veyron fuel pump. Results may vary depending on your engine configuration.

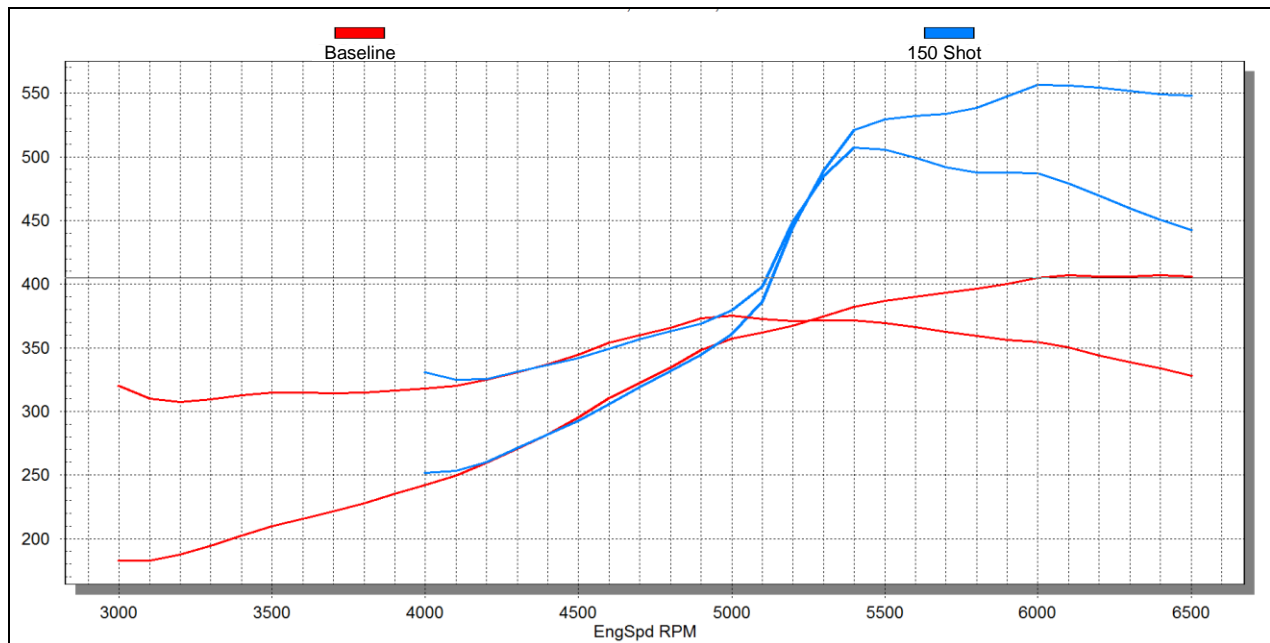

Figure 15 – 150 HP increase using 4X .029 Jets on LSX376-B15 Engine

Chapter 4 Determining Optimum System Performance

The jetting combinations included in your NOS Hi-Ram Nitrous kit are intended to generate power gains of 50 to 250 HP. These combinations are designed to be used with 950 psi of nitrous bottle pressure and 43 psi of flowing fuel pressure. Spark plug inspection and/or the use of a wide-band O₂ sensor can determine optimum system performance. Inspection of the spark plugs should be done on a consistent basis.

1. Perform a dynamometer pull or a full throttle pass down the racetrack. Note the power reading or vehicle mph (not e.t.). Examine the spark plugs for an indication of lean or rich nitrous/fuel conditions (refer figure 16 to for tips on reading the spark plugs). For this application, the air/fuel mixtures at WOT tend to be very rich in stock form. You may wish to examine a plug after a NO-nitrous pass or dyno pull for comparison purposes.

CAUTION! Terminate test immediately if pinging, knocking, detonation is noticed during the test. If engine does not pull hard (expected HP or torque gains are not observed), terminate test and investigate before continuing.

- 1A. If spark plugs appear to be excessively rich, decrease the fuel enrichment.

1B. If spark plugs appear to be excessively lean, increase the fuel enrichment.

1C. If spark plugs have a “like new” appearance on the porcelain and electrode, do not make a fuel enrichment change.

2. Repeat these steps until the desired mixture is obtained.

How to Read Spark Plugs from a Nitrous Oxide Injected Engine

A. Correct Timing, Mixture, and Spark Plug Heat Range

The ground strap retains a “like new” appearance. The edges are crisp, with no signs of discoloration. The porcelain retains a clear white appearance with no “peppering” or spotting.

B. Excessively Rich Mixture

The porcelain may be fuel stained, appearing brown or black. In extreme cases, the ground strap, electrode, and porcelain may be damp with gasoline, or smell of fuel.

C. Detonation

The edges of the ground strap may become rounded. The porcelain has the appearance of being sprinkled with pepper, or may have aluminum speckles. During heavy detonation, the ground strap tip may burn off. This phenomenon can result from excessive ignition timing, too high a heat range spark plug, inadequate fuel octane, or excessively lean mixture.

D. Excessively Lean Mixture

The edges of the ground strap may become rounded. Under moderate overheating, the tip of the ground strap can discolor, usually turning purple, or the entire ground strap can become discolored.

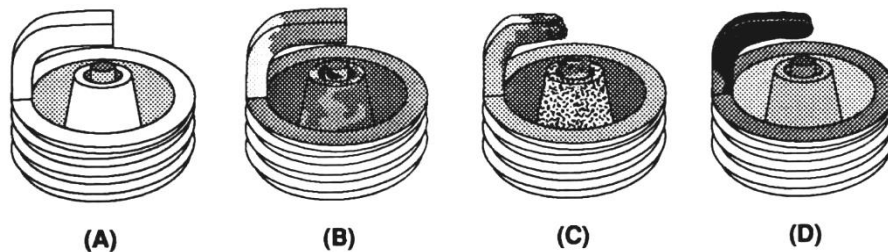

Figure 16 Spark Plug Condition

Chapter 5 Alternate Sensor, Actuator, and Switch Components

1. In some racing applications, “pushbutton solenoid” activation is preferred. In such instances, the solenoid is connected to ground via a pushbutton momentary switch P/N 15610NOS. For information on wiring options, please call **NOS Technical Support at 1-866-464-6553**.
2. Almost all multi-point fuel injection systems are provided with throttle position sensors. NOS has throttle position sensor controllers that activate the solenoids, according to the sensor voltage output. This form of solenoid activation procedure is commonly referred to as “TPS activation”. Such devices are more accurate than the microswitch. For P/Ns on TPS switches and information on wiring options, please call **NOS Technical Support at 1-866-464-6553**.
3. NOS offers fuel pressure safety switches. These switches only allow the nitrous and fuel solenoid to be activated, if a safe fuel pressure is existent in the enrichment fuel supply system. For information on pressure safety switches and information on wiring options, please call **NOS Technical Support at 1-866-464-6553**.
4. Activation of nitrous at low RPM levels can be detrimental to the engine performance and engine life. The RPM window activation switch only allows the nitrous and fuel solenoid to be activated if a safe RPM value has been reached. Some factory engine control units cut off the ignition if a maximum RPM level is reached. Although the engine is still at WOT and the solenoids are activated no nitrous and fuel is combusted. When the engine reaches safe RPM levels ignition is restored but excess fuel and nitrous are present in the manifold. Some applications may even cut the fuel injector to limit engine RPM. Because the engine is at WOT, the nitrous solenoid is still open thus generating an extreme lean condition. Under both conditions engine damage might occur. The RPM window activation switch cuts off the supply of fuel and nitrous until safe RPM levels are reached. The low and high RPM values can be trimmed according to the application. For information on pressure safety switches and wiring options, please call **NOS Technical Support at 1-866-464-6553**.

Chapter 6 Routine Maintenance

6.1 Nitrous Solenoid Filter

When nitrous bottles are refilled, they can become contaminated with debris if the refiller does not have adequate filtration in his transfer pump mechanism. Contaminants in the bottle will eventually become lodged in the nitrous solenoid filter fitting.

Call 1-800-99-REFILL (1-800-997-3345) for bottle refill location information.

You should periodically (after every 20-30 pounds of nitrous usage) examine the mesh in the nitrous filter for debris.

To clean the filter, follow the steps below:

1. Close the valve on the nitrous bottle.
2. Empty the main nitrous feed line.
3. Disconnect the main nitrous feed line from the nitrous solenoid.
4. Remove the nitrous filter fitting from the nitrous solenoid.
5. Remove **all** PTFE paste debris from the solenoid inlet port threads and from the nitrous solenoid filter pipe threads.
6. Examine the mesh in the nitrous filter fitting for contaminants. Blow out debris with compressed air, if necessary.
7. Apply fresh PTFE paste to the nitrous filter pipe threads. Reinstall the filter in the nitrous solenoid.
8. Reconnect the main nitrous supply line to the nitrous solenoid.

6.2 Nitrous Solenoid Plunger

6.2.1 General Information

The seals used in NOS nitrous solenoid plungers are constructed from materials which are designed to be used with nitrous oxide. When kept free from fuel contaminants or from over pressurization, they should provide trouble free performance.

You should periodically (after every 20-30 pounds of nitrous usage) examine the seal in the nitrous solenoid plunger.

The seals used in NOS nitrous solenoid plungers are designed to work at pressures up to 1100 psi. Exposing the plunger to excessive pressure (whether the vehicle is sitting or in-use) can result in the seal in the plunger swelling or in extreme cases disintegrating.

NOTE: The seals are designed so that if they fail due to over pressurization, they will not leak, the valve will just fail to flow nitrous oxide.

Swelling of the nitrous solenoid plunger seal will reduce nitrous flow (causing an excessively rich nitrous/fuel condition and a loss of power).

6.2.2 Nitrous Solenoid Plunger Disassembly and Inspection

1. Close the valve on the nitrous bottle.
2. Empty the main nitrous supply line.
3. Remove the retaining nut from the nitrous solenoid.
4. Remove the coil and housing from the nitrous solenoid base.
5. Unscrew the stem from the nitrous solenoid base. Do this by double nutting the stem, or by using a solenoid stem removal tool. **Do not use pliers on the solenoid stem. Damage to the stem will result.**
6. Remove the stem, spring, and plunger from the solenoid base.
7. Examine the plunger seal for swelling. The seal surface should be flat, except for a small circular indentation in the center of the seal;

A fuel-contaminated seal will protrude from the plunger and be dome-shaped. A fuel-contaminated seal may return to its original shape if left out in the fresh air for several days. It may then be returned to service.

A seal, which has been over-pressurized, may be dome-shaped, or the sealing surface may be flat with the seal protruding out of the plunger. A dome-shaped seal may return to its original shape if left out in the fresh air for several days. It may then be returned to service. A seal, which is flat, but protrudes from the plunger body has probably failed internally and should be replaced.

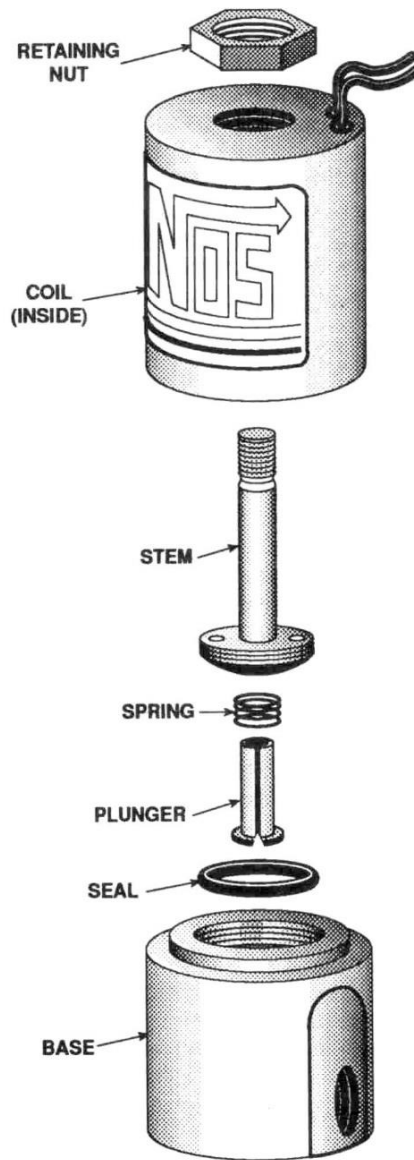

Figure 17 - Exploded View of a Typical Solenoid

Appendix A Troubleshooting Guide

The troubleshooting chart on the following pages should help determine and rectify most problems with your installed NOS system. If you still need assistance determining or fixing problems, call NOS Technical Support Department at 1-866-464-6553.

PROBLEM	POSSIBLE CAUSES	DIAGNOSTIC PROCEDURE	CORRECTIVE ACTION
No change in engine speed when the system is activated.	System wired incorrectly.	Compare wiring to schematic.	Wire per instructions.
	Restricted fuel line.	Inspect fuel line for restrictions (crimped or plugged).	Remove restrictions.
	Malfunctioning fuel solenoid.	Remove and inspect solenoid.	Repair/replace solenoid.
	Malfunctioning nitrous solenoid.	Remove and inspect solenoid.	Repair/replace solenoid.

Engine runs rich when system is activated.	Bottle valve not fully opened.	Check bottle valve.	Open valve fully.
	Bottle mounted improperly.	Check bottle orientation.	Mount bottle properly.
	Plugged nitrous filter.	Inspect filter.	Clean/replace filter.
	Low bottle pressure.	Check bottle temperature.	Set bottle temperature to 80° to 85°F.
	Inadequate nitrous supply.	Weigh bottle.	Fill bottle. 1-800-997-3345 for refills nearest you.
	Mismatched N ₂ O/fuel jetting.	Compare jetting to recommended values.	Install correct jets.
	Excessive fuel pressure.	Install fuel pressure gauge in the fuel line. Measure the pressure during acceleration, with the system activated.	Regulate pressure down, or install smaller fuel jetting.
	Loose nitrous solenoid wiring.	Inspect the solenoid wiring.	Repair wiring.
	Malfunctioning nitrous solenoid.	WARNING: <i>Solenoid discharges nitrous at a high rate. Don't inhale nitrous; death may occur. Skin contact may cause frostbite.</i> Close bottle valve. Disconnect the solenoid outlet port. Disconnect the solenoid (+) lead. Open the nitrous bottle valve. Briefly connect the +12V to the solenoid. Solenoid should discharge N ₂ O at a high rate.	Repair/replace solenoid.
No change in performance when system is activated.	System wired incorrectly.	Compare nitrous wiring to schematic.	Wire system per instr.
	Loose ground wire(s).	Connect 12V test light to battery (+) terminal. Check for continuity at grounds noted in schematic.	Tighten/repair loose ground(s).
	No power to arming switch.	With vehicle ignition on, connect 12V test light to battery (-) terminal. Check for power at pole #1 on arming switch.	Repair wiring.
	Damaged fuse in switched power (15 amp)	Remove and inspect 15 amp fuse	Replace Fuse
	Damaged fuse in solenoid relay battery power (30 amp)	Remove and inspect 30 amp fuse	Replace Fuse
	Malfunctioning arming switch.	With vehicle ignition on, turn arming switch ON. Connect 12V test light to battery (-) terminal. Check for power at red wire on arming switch.	Replace arming switch.
	Malfunctioning Progressive Controller	Refer to the installation instructions for the NOS Mini 2-Stage Controller, part number 15974NOS	
Engine detonates mildly when system is activated.	Overly rich fuel condition.	Check for black smoke or backfiring through exhaust with system activated.	Install smaller fuel jet or check for restriction in fuel supply.
	Inadequate octane fuel.		Use higher octane fuel; up to 116VPC-16.
	Incorrect spark plug type or heat range.	Do not use "fine wire" or iridium type spark plugs. Reduce spark plug heat range by 1 or 2 steps.	Replace spark plugs with correct type and heat range.
Engine detonates heavily when system is activated.	Too much nitrous flow.		Reduce nitrous jetting.
	Inadequate fuel delivery due to restricted fuel filter.	Inspect fuel filter.	Clean or replace filter.
	Crimped fuel line.	Inspect fuel line.	Replace crimped line.
High rpm misfire when system is activated.	Weak fuel pump.	Install fuel pressure gauge. Run engine under load at wide-open throttle, with system activated.	Repair/replace fuel pump.
	Excessive spark plug gap.	Inspect spark plugs.	Set spark plug gap at 0.030" to 0.035".
Surges under acceleration when system is activated.	Weak ignition/ignition component failure.	Inspect components (plug wires, coils, etc.)	Replace worn components.
	Inadequate supply of nitrous.	Check bottle weight.	Replace with full bottle.

Nitrous Oxide Accessories

NOS systems are calibrated for optimum performance with a bottle pressure of 950 psi. The pressure will change with temperature. Heater kits are thermostatically controlled to keep the bottle near 85° F to provide correct pressure. **Bottle Heater (P/N 14164NOS)** is available for 10 & 15 lb. bottles. **Bottle Heater, P/N 14169NOS**, is pressure-controlled to keep your bottle at 950 psi.

Insulating the bottle helps maintain pressure by keeping heat in the bottle when it's cold, or heat out when it's hot outside. The blankets are made of a rugged, easily cleaned Nylon outer shell with insulation. It's also an excellent "dress up" accessory and perfect for "covering" battle-scarred bottles. **Bottle Blanket (P/N 14165NOS)** is a 7" diameter blanket for the 10 lb. bottle.

#10 Bottle Heater P/N 14169NOS



#10 Bottle Blanket P/N 14165NOS



The **Nitrous Pressure Gauges, P/N 15910NOS (-4AN lines) or P/N 15912NOS (-6AN lines)** [0-1500 PSIG] are designed to provide accurate ($\pm 2\%$ of full scale) readings of fuel pressure in carbureted applications.

The **Fuel Pressure Gauges, P/N 15906NOS** [0-120 PSIG] **and P/N 15900NOS** [0-15 PSIG] are engineered to provide accurate ($\pm 2\%$ of full scale) readings for high and low fuel pressure applications.

Nitrous & Fuel Pressure Gauges





NOS Technical Support
Toll-Free Phone: 1-866-464-6553
Phone: 1-270-781-9741

**For online help, please check the Tech Service
section of our website: www.holley.com**

**For refill information:
1-800-99-REFILL (1-800-997-3345)**

199R11650
Date: 9-20-18