



AEROMOTIVE Part # 17166 & 17167 INSTALLATION INSTRUCTIONS

This product is not legal for sale or use on emission-controlled vehicles except when used as a direct replacement part matching OEM specification.

WARNING!



Always be aware of flammable situations. Drilling and grinding can be potential ignition sources. Extinguish all open flames, prohibit smoking and eliminate all sources of ignition in the area of the vehicle and workspace before proceeding with the installation. Ensure you are working in a well ventilated area with an approved fire extinguisher nearby.

WARNING!



etc.

Installation of this product requires modification to a fuel tank/ the fuel system, failure to satisfy all safety considerations will result in fire, explosion, injury and/or loss of life to yourself and/or others. All fuel system components **MUST** be located as far from heat sources as possible, like exhaust, engine block,

WARNING!



Mechanical and hydraulic lifting devices can tip over or lower accidentally due to incorrect maneuvering or technical errors. A falling object can cause injury and/or loss of life to yourself and/or others. When working under the vehicle, always use stands, and ensure that the ground or floor is stable and level. Never crawl under a vehicle which is only supported by a jack.

WARNING!



The fuel system is under pressure. Do not open the fuel system until the pressure has been relieved. Refer to the appropriate vehicle service manual for the procedure and precautions for relieving the fuel system pressure.

CAUTION!



When installing this product always wear safety glasses and other appropriate safety apparel. A drilling operation will cause flying metal chips. Flying metal chips can cause eye injury.

CAUTION:



Installation of this product requires detailed knowledge of automotive systems and repair procedures. We recommend that this installation be carried out by a qualified automotive technician. Careless installation of this product can result in damage to the product, injury or loss of life to yourself and/or others.

Compatible Fuels:

Pump Gas
Race Gas
E85
Alcohol/Ethanol

Parts Included:

1ea p/n 18688 Phantom 340 or 18689 Phantom 200	1ea p/n 15118 3/8 Quick Connect to AN-08
1ea p/n 12321 Filter 10 micron Paper	1ea p/n 15605 AN-08 ORB to AN-06 flare
1ea p/n 12305 Filter Bracket	6 ea p/n 15606 AN-06 ORB to AN-06 flare
1ea p/n 13131 Fuel Pressure Regulator (Not available for individual sale, see Aeromotive p/n 13109)	2 ea p/n 15609 AN-10 ORB to AN-06 flare
1ea p/n 16307 Fuel Pump Wiring Kit.	1ea p/n 15633 Gauge, 0-100 psi

Aeromotive system components are not legal for sale or use on emission controlled motor vehicles. Phantom Systems are designed for use with gasoline based fuels only, up to 15% ethanol mix maximum.

The enclosed Aeromotive Fuel System Kit is designed to give the end user a basic EFI fuel system, less the AN fuel lines and hose-ends, for an return style EFI application utilizing OEM "Returnless" fuel rails. The 3/8" Quick-Connect and AN-06 adapter included is suitable to adapt the stock fuel rail inlet to an AN-06 fuel line connection. This is the ideal Phantom System Kit to enable transplanting many late-model domestic and some import engines with OEM Returnless Fuel rails, including many of the popular LS series GM and Mod-Motor series Ford engines, whether stock takeout or crate motors.

A return line of AN-06 or 3/8" equivalent diameter must be installed from the regulator back to the tank, after which base fuel pressure will be adjustable in a range between 38-60 PSI. The included regulator also provides 1:1 ratio vacuum/boost reference, making the system suitable for all EFI engines, both Naturally Aspirated and Forced Induction.

This installation instruction provides a diagram that outlines the overall layout of the fuel system intended with the enclosed components. The system diagram illustrates the components used, their locations relative to each other and in relation to fuel flow, including general fuel line routing and the AN fuel line sizes required. This is a system overview. Please refer to each individual component's installation instructions for detailed installation help with that particular component. Please contact Aeromotive for any recommendations on fuel line or additional fitting requirements.

Failure to follow the above recommendations may result in fuel leakage, bursting of the fuel lines, poor vehicle performance and/or decreased fuel pump life! Improper installation will void all warranties for this product!

Aeromotive Commonly Used Port Fittings:

15605 - ORB-08 to AN-06 Flare
15606 - ORB-06 to AN-06 Flare
15609 - ORB-10 to AN-06 Flare
15615 - 3/8-NPT to AN-06 Flare

Aeromotive Commonly Used Hose-Ends:

15650 - AN-06 Straight Hose End
15651 - AN-06 45-Deg. Hose End
15652 - AN-06 90-Deg. Hose End

Aeromotive Commonly Used SS Braided Fuel Line:

15701 - AN-06 4' Length
15702 - AN-06 8' Length
15703 - AN-06 12' Length

Aeromotive Replacement Element Part Numbers:

12601 – 10-M Fabric Element (For all ORB-10 Filters)
12635 – 40-M SS Element (For all ORB-10 Filters)
12604 – 100-m SS Element (For all ORB-10 Filters)
12001 – Filter O-Ring, 10-Pack (For all ORB-10 Filters)

General Installation Cautions and Guidelines:

- **CAUTION:** Insure all components are mounted, and fuel lines are routed through the chassis per the diagram, and in a manner to clear any exhaust system components, especially exhaust headers, turbo charger down-pipes, mufflers and tail-pipes, etc.
- **CAUTION:** Insure all components are mounted, and fuel lines are routed through the chassis per the diagram, and in a manner to safely clear any suspension components in the vehicle.
- **CAUTION:** Insure all components are mounted, and fuel lines are routed through the chassis per the diagram, and in a manner to safely clear any transmission, bell-housing and or drive-line components.
- **CAUTION:** Pressurize the fuel system and thoroughly check for fuel leaks, repairing any leaks found first, before cranking and/or starting the engine. Once the engine is running, again carefully check for fuel leaks, shutting down the vehicle immediately if necessary to perform any required repairs.
- **GUIDELINE:** Mount the Phantom Fuel Pump in the deepest part of the fuel tank.
- **GUIDELINE:** Mount the fuel pressure regulator in the engine bay, as close to the fuel rail/carb as possible.
- **GUIDELINE:** Terminate the main, 10-gauge power for the included fuel pump wiring harness directly from the back of the alternator charging stud, or directly off the battery (+) post. Terminate the 10-gauge fuel pump ground wire to either end of the battery ground (-) cable, at the battery or chassis connection point.
- **GUIDELINE:** Acquire and install quality AN style hose and hose-ends. Teflon or PTFE based fuel line, though more costly, offers both long service life and resistance to permeation or vapor walk (where fuel vapors can “walk” through the line and contribute fuel smell to the area around where the car is stored).

EFI Return Style OEM Returnless Rail

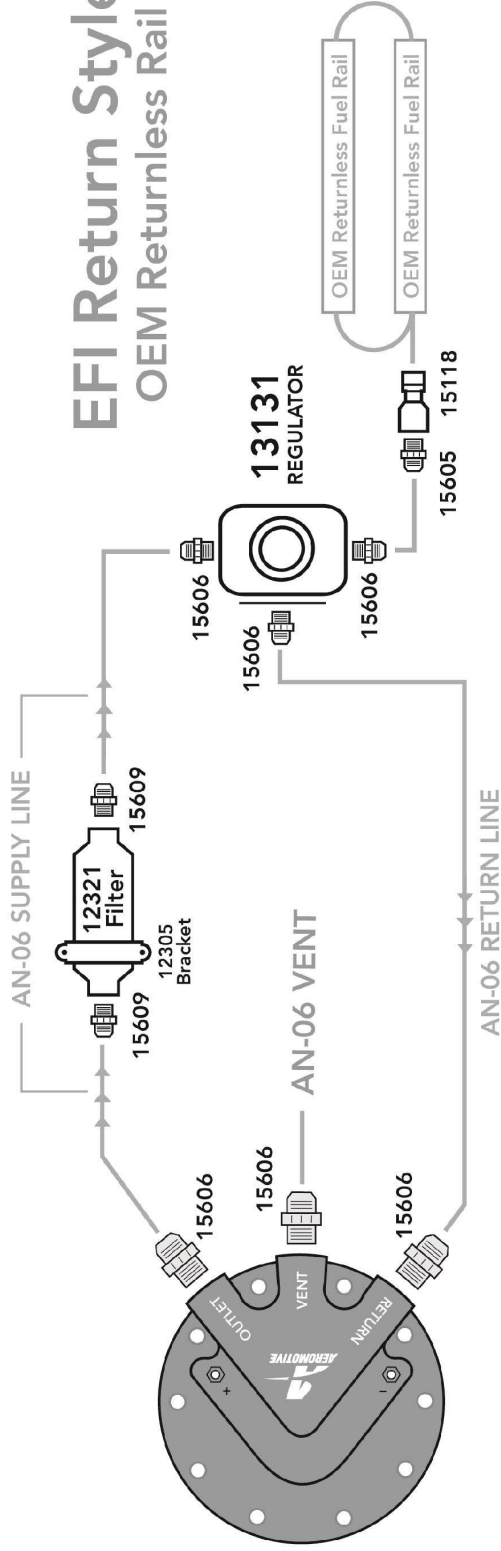

Contact Us

RGA NUMBER REQUIRED FOR ALL RETURNS TO AEROMOTIVE.

To obtain an RGA number, please call (913) 647-7300 and ask for the Returns and Repairs department or complete the online form under the "Rebuilds" section at www.aeromotiveinc.com.

- **Shipping & Returns**

Aeromotive Inc.
10955 Mill Creek Road
Lenexa, KS 66219

General Inquiries and Tech Line: (913) 647-7300

General Email: info@aeromotiveinc.com

Tech Email: tech@aeromotiveinc.com

The Aeromotive Tech Lines are open Monday through Friday from 9:30AM to 5:00PM Central Standard Time.



WARNING: This product can expose you to chemicals, including chromium, which is known to the State of California to cause cancer or birth defects or other reproductive harm. For more information, visit: www.p65Warnings.ca.gov

AEROMOTIVE, INC. LIMITED WARRANTY

This Aeromotive Product, with proof of purchase dated on or after January 1, 2003, is warranted to be free from defects in materials and workmanship for a period of one year from the original date of purchase. No warranty claim will be valid without authentic, dated proof of purchase.

This warranty is to the original retail purchaser and none other and is available directly from Aeromotive and not through any point of distribution or purchase.

If a defect is suspected, the retail purchaser must contact Aeromotive directly to discuss the problem, possible solutions and obtain a Return Goods Authorization (RGA), if deemed necessary by the company. Please call 913-647-7300 and dial option 3 for the technical service dept. All returns must be shipped freight pre-paid to the company and with valid RGA before they will be processed.

Aeromotive will examine any product returned with the proper authorization to determine if the failure resulted from a defect or from abuse, improper installation, misapplication or alteration. Aeromotive will then, at it's sole discretion, return, repair or replace the product.

If any Aeromotive product is determined defective, buyer's exclusive remedy is limited in value to the sale price of the good. In no event shall Aeromotive be liable for incidental or consequential damages.

Aeromotive expressly retains the right to make changes and improvements in any product it manufactures and sells at any time. These changes and improvements may be made without notice at any time and without any obligation to change the catalogs or printed materials.

Aeromotive expressly retains the right to discontinue at any time and without notice any Aeromotive product that it manufactures or sells.

This warranty is limited and expressly limits any implied warranty to one year from the date of the original retail purchase on all Aeromotive products.

No person, party or corporate entity other than Aeromotive shall have the right to: determine whether or not this Limited Warranty is applicable to any Aeromotive product, authorize any action whatsoever under the terms and conditions of this Limited Warranty, assume any obligation or liability of any nature whatsoever on behalf of Aeromotive under the terms and conditions of this Limited Warranty.

This Limited Warranty covers only the product itself and not the cost of installation or removal.

This Limited Warranty is in lieu of and expressly excludes any and all other warranties, expressed or implied. This Limited Warranty gives you specific legal rights, and you may also have other rights which vary from state to state.