

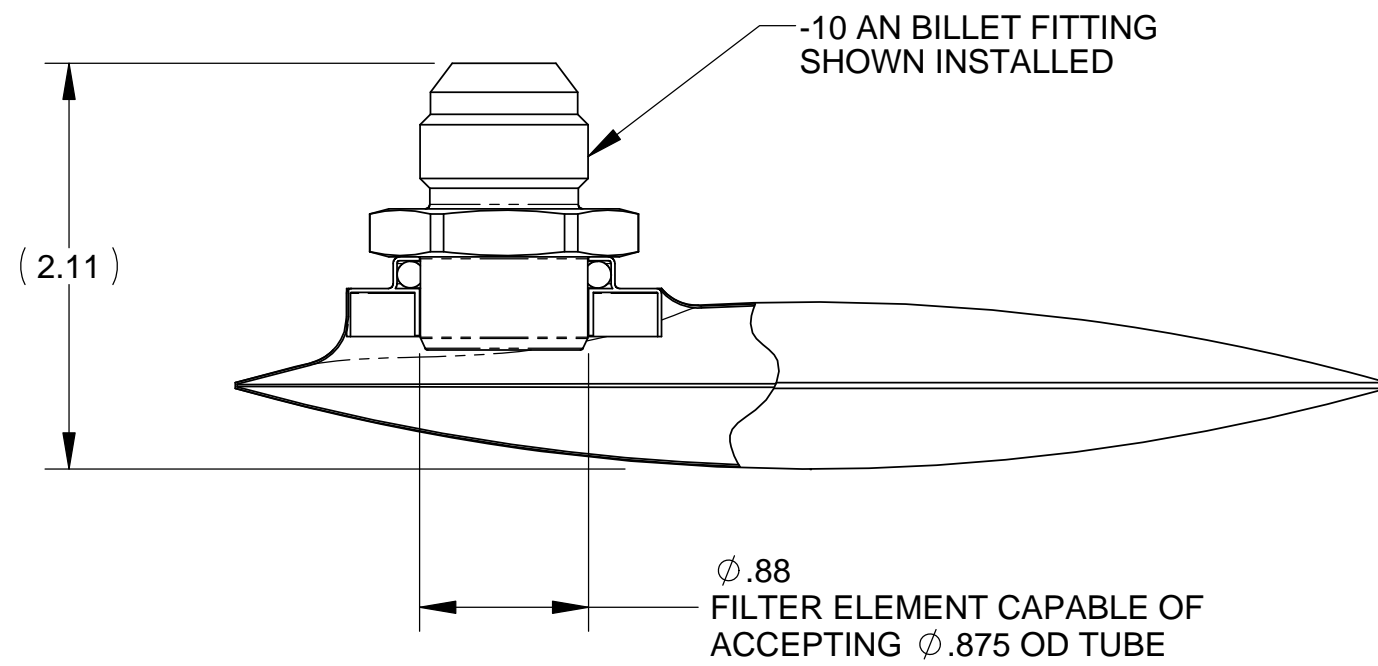

NOTES:

1. THIS DRAWING DESCRIBES THE FUELAB 83801 FUEL FILTER.
2. FEATURES INCLUDE:
 - HIGH FLOW CAPACITY, UP TO 250 GPH
 - BILLET ALUMINUM -10AN FITTING END INCLUDED
 - STAINLESS STEEL 75μ RELATIVE RATED ELEMENT
 - INTERNAL SPRING TO PREVENT COLLAPSE
3. FUEL COMPATIBILITY INCLUDES:
 - GASOLINE (PUMP OR RACE)
 - METHANOL
 - ETHANOL (INCLUDING E85)
 - DIESEL
4. BILLET ALUMINUM FITTING INCLUDED, BAGGED SEPARATELY FROM FILTER.
5. REFERENCE DRAWING 1080203A1 FOR ASSEMBLY INSTRUCTIONS.

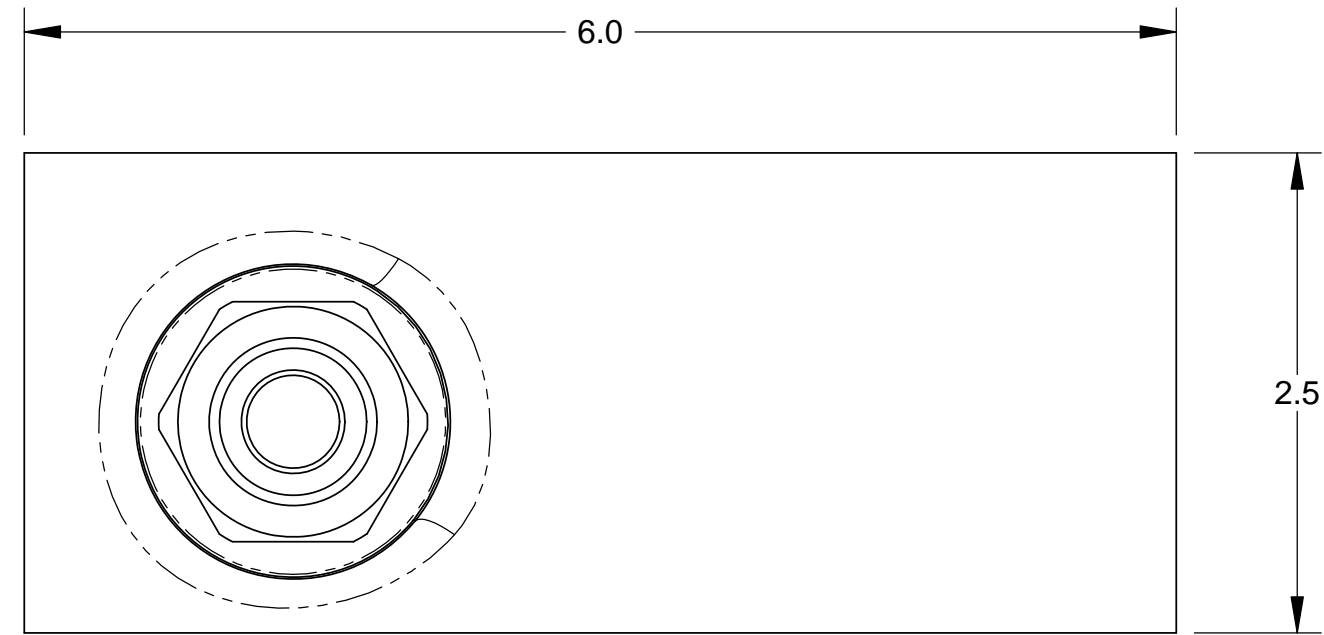

PARTIAL SECTION VIEW SHOWN ABOVE

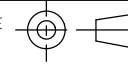
UNLESS OTHERWISE SPECIFIED:		 <small>DIGITAL FUEL DELIVERY</small> Litchfield, Illinois	
<small>INTERPRET DWG PER ANSI Y14.5 DIMENSIONS ARE IN INCHES TOLERANCES: FRACTIONAL: ±1/64" ANGULAR: ± 1/2° DECIMALS: X±1 .XX±.03 .XXX±.010 SURFACE FINISH 128 OR BETTER BREAK ALL SHARP EDGES .010 MAX REMOVE ALL BURRS</small>		TITLE: <h3 style="text-align: center;">FILTER, IN-TANK, MODEL 83801</h3>	
SIZE <h2 style="font-size: 2em;">C</h2>	DWG. NO. <h2 style="font-size: 1.5em;">108020300</h2>	REV <h2 style="font-size: 1.5em;">A</h2>	
<small>THIRD ANGLE PROJECTION</small> 		SCALE: 1/1	WEIGHT: .16 LB SHEET: 1 OF 1
DO NOT SCALE DRAWING			