

Haltech Off-Road Usage Policy

It is unlawful to tamper with your vehicle's emissions equipment. Haltech products are designed and sold for sanctioned off-road/competition non-emissions controlled vehicles only. Using Haltech products for street/road use on public roads is prohibited by law. It is the responsibility of the installer and/or user of this product to ensure compliance with all applicable local and federal laws and regulations. Please check with your local vehicle authority before using any Haltech product

Installation of Haltech Products

No responsibility whatsoever is accepted by Haltech for the fitment of Haltech Products. The onus is clearly on the installer to ensure that both their knowledge and the parts selected are correct for that particular application. Any damage to parts or consequential damage or costs resulting from the incorrect installation of Haltech products are totally the responsibility of the installer.

Haltech Limited Warranty

Unless specified otherwise, Haltech warrants its products to be free from defects in material or workmanship for a period of 12 months from the date of purchase. Proof of purchase in the form of a copy of the original purchase invoice, receipt or bill of sale which indicates that the product is within the warranty period, must be presented to obtain warranty service. If the Haltech product is found to be defective as mentioned above, it will be replaced or repaired if returned prepaid along with proof of purchase. This shall constitute the sole liability of Haltech. To the extent permitted by law, the foregoing is exclusive and in lieu of all other warranties or representations, either expressed or implied, including any implied warranty of merchantability or fitness. In no event shall Haltech, be liable for special or consequential damages.

Product Returns

Please include a copy of the original purchase invoice, receipt or bill of sale along with the unused, undamaged product and its original packaging. Any product returned with missing accessory items or packaging will incur extra charges to return the item to a re-saleable condition. All product returns must be sent via a freight method with adequate tracking, insurance and proof of delivery services. Haltech will not be held responsible for product returns lost during transit. The sale of any sensor or accessory that is supplied in sealed packaging is strictly non-refundable if the sealed packaging has been opened or tampered with. This will be clearly noted on the product packaging. If you do not accept these terms please return the sensor in its original unopened packaging within 30 days for a full refund.

Returning a sensor or accessory product within 30 days of purchase: Product may be returned for credit or full refund. (Any sealed packaging must not have been opened or tampered with)

Returning a sensor or accessory product after 30 days of purchase: Product may be returned for credit only (no refunds given) and is subject to a 10% Restocking fee. (Any sealed packaging must not have been opened or tampered with)

Template #2



HT-030202

Solid State Relay 100 AMP

Suits: Auxiliary injector or variable pump/fan speed control etc
Includes: 1K Pull up resistor

This device is **strictly non-refundable** if this packaging has been opened or tampered with. This device has been individually electronically tested before packaging and is sold "as is" and without any further warranty. If you do not accept these terms please return this device in its original unopened packaging for a full refund.

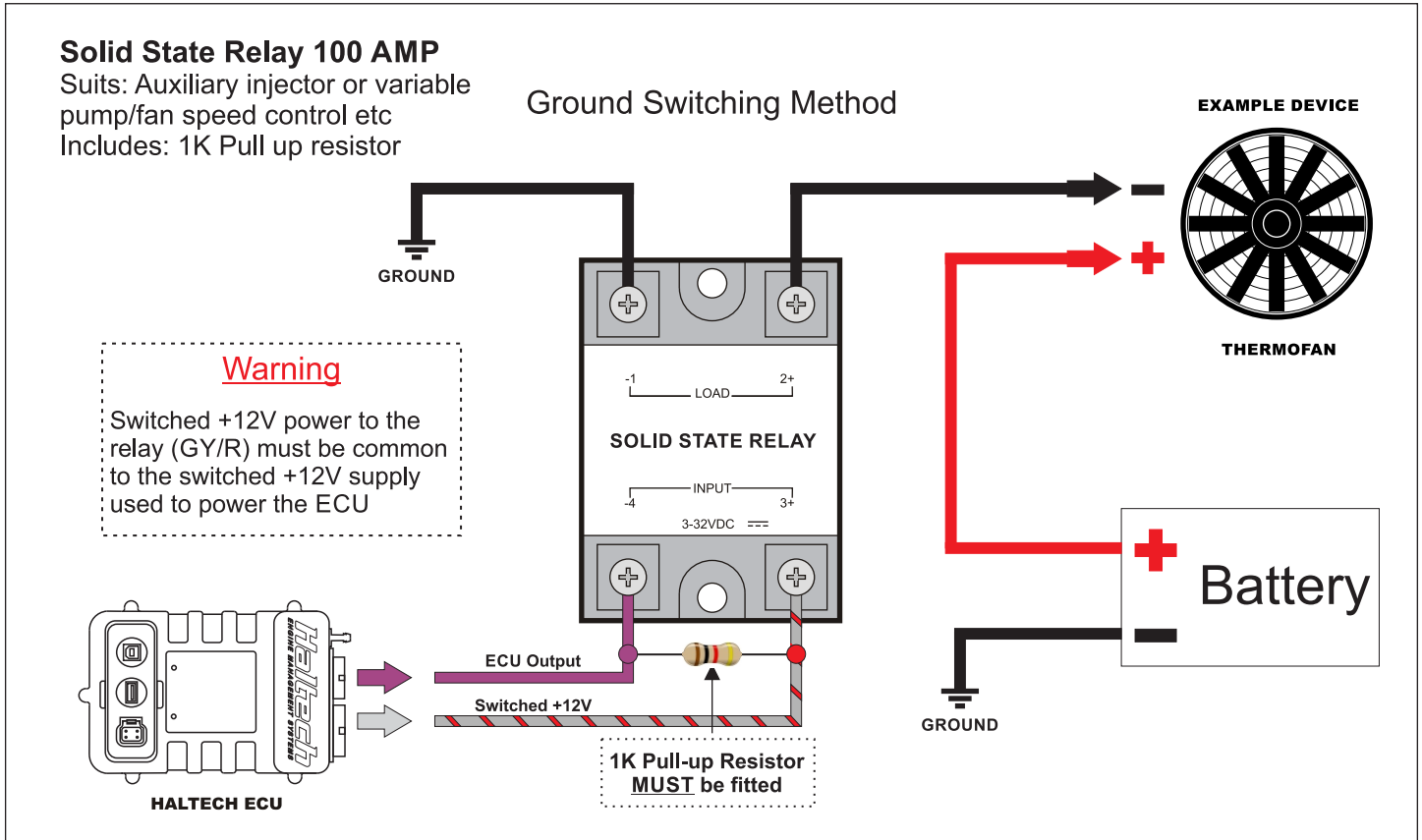

<p>HT-030202</p>		<p>Need more help?</p> <p>Intl: +61 2 9729 0999 USA: +1 888 298 8116</p>	<p>support@haltech.com usasupport@haltech.com</p>
<p>Revision #4</p>	<p>www.haltech.com</p>	<p>YouTube /Haltechecu</p>	<p>f /HaltechEngineManagement</p>

EXAMPLE DEVICE

Power Switching Method

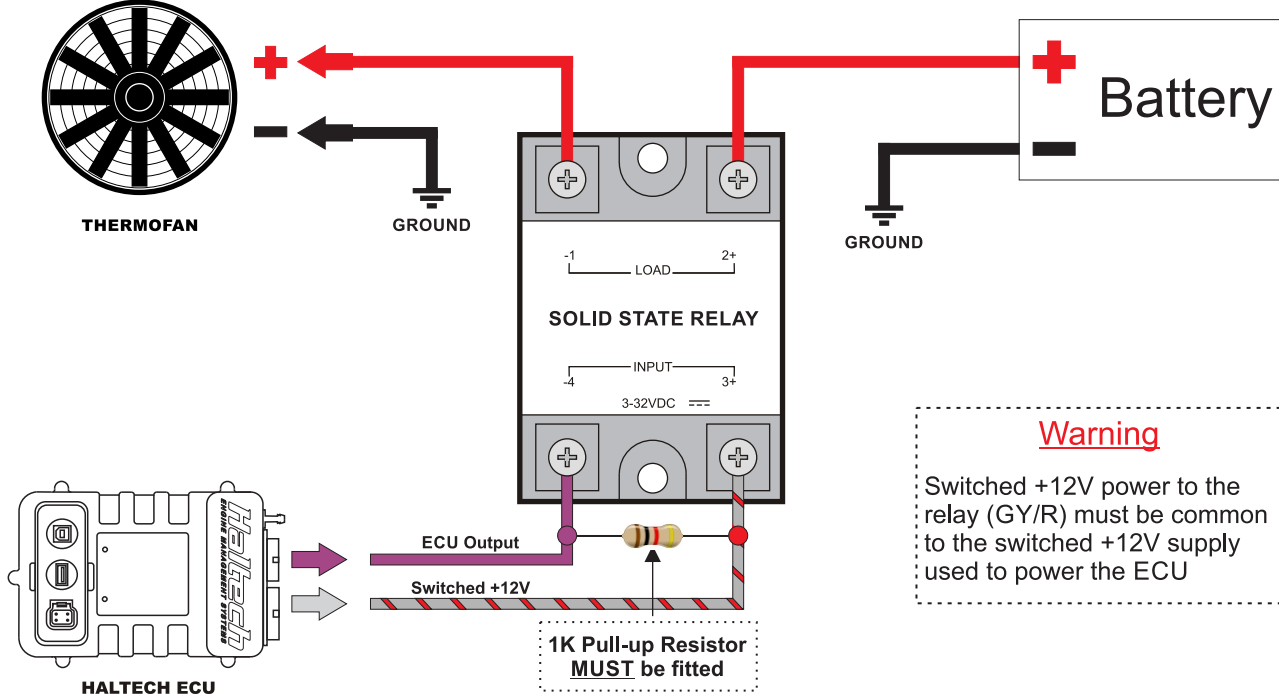

Warning
 Switched +12V power to the relay (GY/R) must be common to the switched +12V supply used to power the ECU

HT-030202
 Revision #4



Need more help?
 Intl: +61 2 9729 0999
 USA: +1 888 298 8116
 support@haltech.com
 usasupport@haltech.com
 www.haltech.com
 /Haltececu
 /HaltechEngineManagement