



Installation Instructions

D760-0075:

COLD AIR INTAKE SYSTEM

2020-24 G01 X3 M40i (LCI)

2020-25 G02 X4 M40i (LCI)

Document Revision: A

Release Date: October 29, 2024

Table of Contents

PARTS LIST	2
REMOVAL OF STOCK SYSTEM	3
INSTALLATION OF DINAN SYSTEM.....	5

Thank you for being selective enough to choose a Dinan Performance Intake System. The Dinan Engineering Team has spent many hours developing this product to assure that you will receive increased performance, durability and an aesthetic design that you as a customer will be able to enjoy for many years. Ease of installation and maintenance is important to us and has been highly considered throughout the design process.

Prior to performing the installation, familiarize yourself with these instructions as it should help you with the process. If you feel that you do not have the required skills or tools, please arrange for a qualified repair facility to perform the installation.

If you have any difficulties during the installation, or if these instructions are not clear to you, please call Dinan's Technical Support Staff at (800) 341-5480.

Again, thank you for choosing Dinan. Enjoy.

PARTS LIST

ITEM NO.	PARTNO	DESCRIPTION	QTY.
1	D401-0030	AIR FILTER, F95 X5M	1
2	D671-0246	WASHER, RUBBER, 0.195 ID X 0.438 OD, BLK	5
3	D671-0257	M4 WAVE WASHER	4
4	D671-0147	M4 X 10 X 0.7P BUTTON HEAD, SS	6
5	#48Z	CLAMP, 9mm, 80-100	2
6	M4X12 FENDER	M4 WASHER	4
7	D340-0434	SI HOSE 3.63 X 3.63 X 2.2	1
8	D760-0311	AIRBOX LID, G01 LCI	1
9	D762-0312	INLET TUBE, G01	1

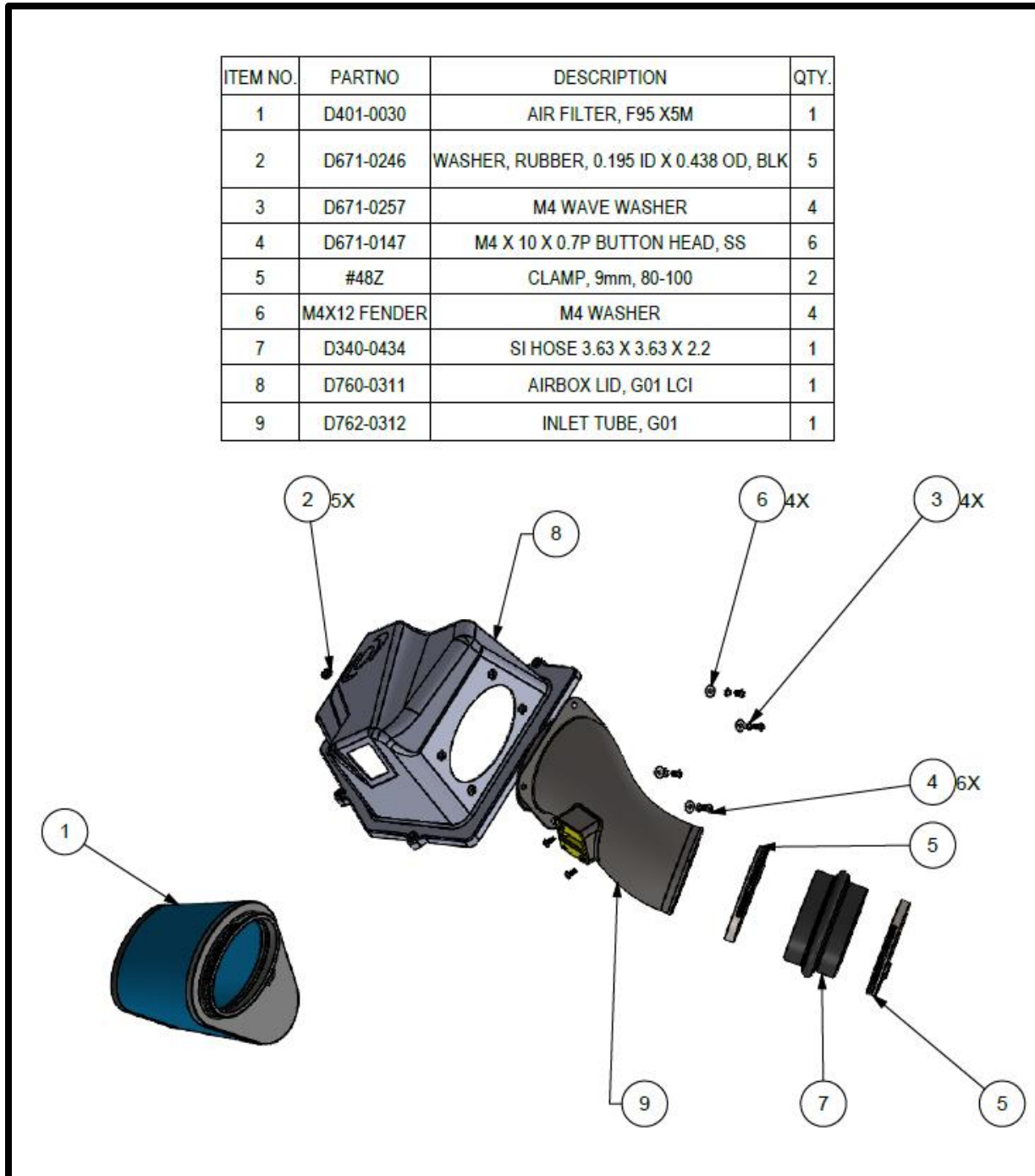

REMOVAL OF STOCK SYSTEM

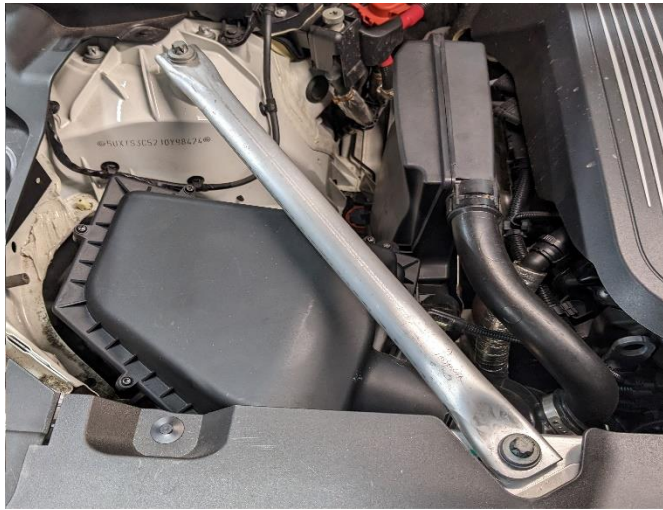

STEP 1:

Remove brace

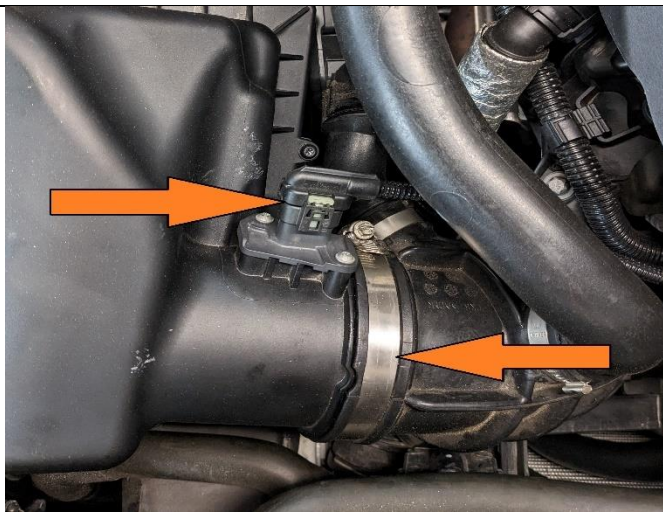

STEP 2:

Unclip and detach connector from sensor

Loosen clamp

**STEP 3:**

Remove airbox assembly from vehicle

Ensure the 3 rubber grommets remain in position as shown

**STEP 4:**

Loosen clamp at bottom of main intake silencer

Remove intake silencer from vehicle

At this step, everything is removed from the vehicle

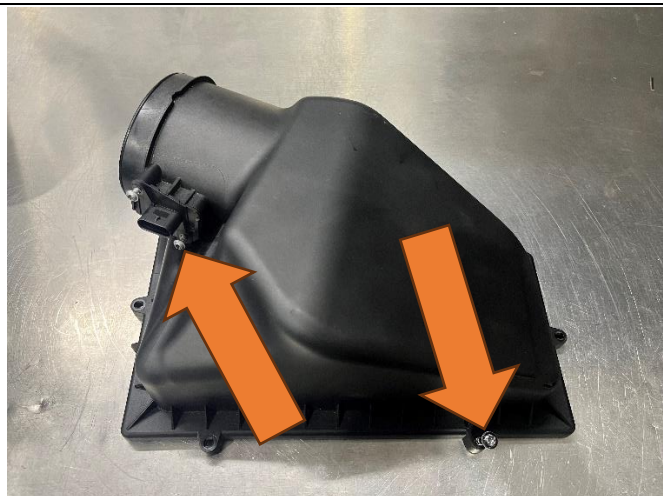
**STEP 5:**

Remove sensor from upper stock box. The sensor will be re-used. The screws will not be re-used

Remove the upper box from the lower box

Fully remove screws from upper box as these will be re-used

INSTALLATION OF DINAN SYSTEM

**STEP 1:**

Slide one clamp over the opening of the inlet hose

Fully seat the inlet hose against the stock turbo inlet housing

Tighten clamp

At this time, slide the other clamp onto the top and tighten slightly to hold into place. Final tightening will be completed once the Intake System is installed.

**STEP 2:**

Position the sensor on the inlet tube. This will only fit in one direction.

Use the M4x10 (2) screws and tighten sensor to inlet tube as shown

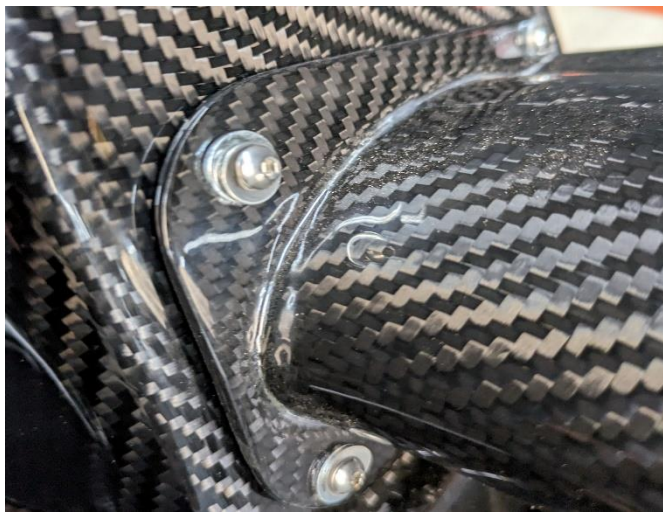

STEP 3:

Slide the outlet tube through the opening and tighten to box (3x)

Hardware shall be in the following order:

Flat Washer – Wave washer – Screw

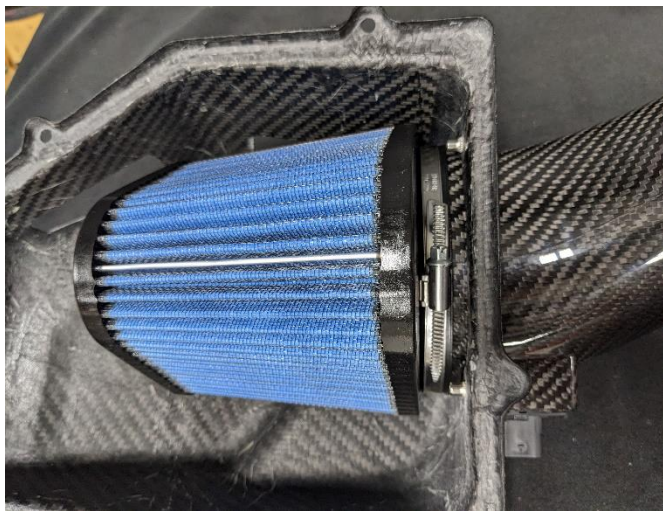
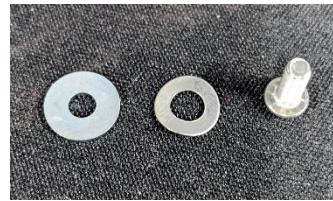

STEP 4:

Position clamp onto collar of air filter

Slide air filter onto tube



STEP 5:

Ensure filter is in correct orientation

See image of Dinan logo and box

Once positioned, tighten clamp

**STEP 6:**

Position the airbox lid onto the stock lower box

Re-using the stock screws, slide the rubber washers onto each one

Secure the airbox lid to the lower box. Tighten until the rubber washer is slightly compressed. Do not overtighten

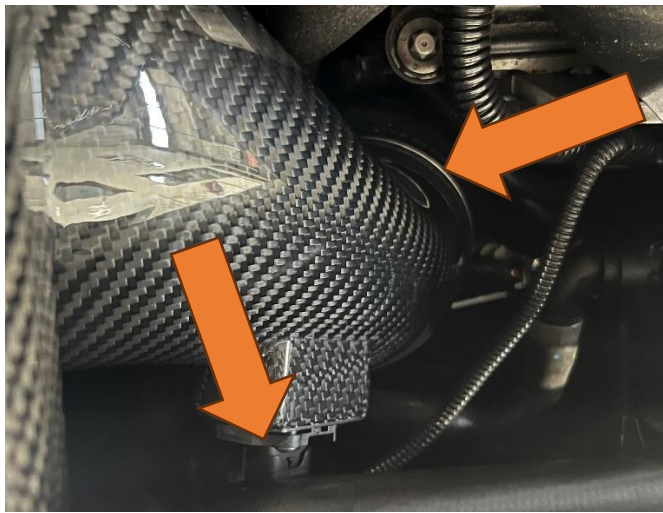
**STEP 7:**

Position the Dinan intake system into the vehicle

Ensure that the outlet tube slides into the inlet hose

Ensure that the airbox assembly seats fully into the rubber grommets

Tighten the clamp as shown

Re-connect the sensor connector. Note that the sensor has been relocated to the front side of the intake tube. Pull on the sensor connector to verify that it has latched completely

**STEP 8:**

Ensure the system is properly seated, all clamps are tightened and the sensor is connected

Re-install the brace and tighten the bolts to 56Nm (41 ft lbs)

ENJOY!